

Thick Turret Tools Products Catalog

1998–2021

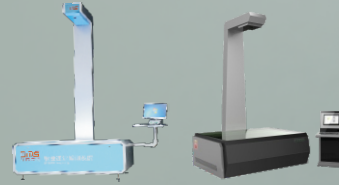

2016

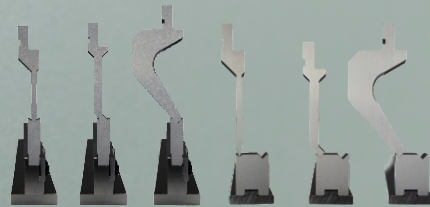

2012



2006



2004



2003



2002



1998



Simply order-with the correct specifications for the right tool.

Have you thought of everything?

Machine Brand/Machine Model/Machine Tonnage

Tooling Series/Tooling Station/Tooling Size

CAD Drawing/DXF File/DWG File

Sheetmetal Material/Sheetmetal Thickness

Special Treatment/TiCN/KPM/Deep Freeze

Special Requires/Rooftop/Whisper/Slugfree/Taper

Order Quantity/Order Delivery Time

Desired Shipping Date

KETEC OVERSEAS DEPARTMENT

KETEC PRECISION TOOLING CO.,LTD
No.7 Lifeng Road, Mingzhu Industrial Park,
Conghua, Guangzhou, China. 510931
Email: simon@ketectool.com
Email: market@ketectool.com
Mob/Whatsapp: +86 137 6069 2768
Mob/Skype: +86 188 1981 5253
Homepage: www.ketectool.com



P1-P2	Thick Turret Tools Overview
P3-P17	Thick Turret A Station
● P3	A STN-Thick Turret Punch Ass'y Index
● P4-P8	T85/Light Duty/Fully Guided/Open Guide/ABS/Slitting
● P9-P10	T90/ABS/Heavy Duty
● P10-P13	E85/Light Duty/E80/Heavy Duty/KU
● P14-P15	85 Punch/90 Punch/80 Punch/KU Punch/ABS Punch
● P16-P17	A STN Dies/Punch Head Ass'y
P18-P33	Thick Turret B Station
● P18	B STN-Thick Turret Punch Ass'y Index
● P19-P23	T85/Light Duty/Fully Guided/Open Guide/ABS
● P23-P25	T90/ABS/Heavy Duty
● P25-P29	E85/Light Duty/E80/Heavy Duty/Special Height/KU
● P29	B STN 90 Stripper/KU Stripper
● P30-P33	B STN Punch/Guide/Die/Punch Head Ass'y
P34-P44	Thick Turret C Station
● P34-P37	C STN-T85/ABS/Fully Guided/Light Duty
● P38-P39	C STN-T90/ABS
● P40	C STN-E85
● P41	C STN-85 Punch/ABS/Slitting/90 Punch/Cluster Punch
● P42-P43	C STN-85 Stripper/90 Strippe/Die/Special Die
● P44	C STN-Guide/Punch Head Ass'y/Guide Ass'y
P45-P57	Thick Turret D Station
● P45-P50	D STN-T85/ABS/Fully Guided/Light Duty/Close To Clamp
● P51-53	D STN-T90/ABS/E85
● P54-P57	D STN-85, 90/Punch/ABS/Slitting/Stripper/Guide Ass'y/Die
P58-P69	Thick Turret E Station
● P58-P65	E STN-T85/T90/E85/ABS/Slitting/Close To Clamp
● P66-P69	E STN-85, 90/Stripper/Guide/Guide Ass'y/Punch Head Ass'y
P70-P72	Multi Tools For Thick Turret



THICK TURRET TOOLING

Punch hole
Blanking



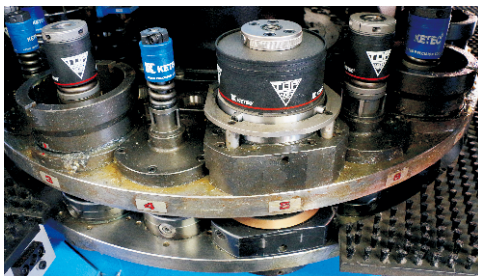

Thick Turret CNC Punching Machine

Thick turret CNC punching machine (Long guide CNC punching machine), tooling stations are: A/B/C/D/E (E is not for all). Punch Ass'y height is between 208.5 and 210.0mm, die height is 30.0mm, punch range is between 1.0 and 114.3mm, material thickness range is between 0.5 and 6.0mm. Thick Turret CNC Punching Machine is the most popular type in the world nowadays, about 70% in the sheetmetal processing market. The most popular brands in China market as below:



A STN-Thick Turret Punch Ass'y Index

THICK TURRET
A STN

T Series



E Series



K Series

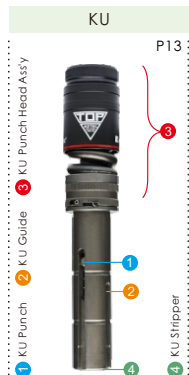

T85 Fully Guided/SPS: T85 Fully Guided/Slitting Punch System
 T85 ABS FG/SPS: T85 ABS Fully Guided/Slitting Punch System
 T85 LD FG/SPS: T85 Light Duty Fully Guided/Slitting Punch System
 T90 Heavy Duty SH: T90 Heavy Duty Special Height

A STN (Size Range:ΦD:1.0~12.7mm)

THICK TURRET A STN

T85 A STN		Slot/Pin	Description	Size(e.g.)
1# Punch Ass'y/Thick Turret T85 Punch Ass'y				
	1 Slot	PA/TT T85 PA/A		RO Φ5
	1 Slot	PA/TT T85 PA/A/TiCN		RO Φ5
	1 Slot	PA/TT T85 PA/A/KPM		RO Φ5
	(0,90)	PA/TT T85 PA/A		RE 2*10
	(0,90)	PA/TT T85 PA/A/TiCN/Blanking		OB Φ3*10-0.3
	(0,90)	PA/TT T85 PA/A/KPM		HX A=S=7.1
	(0,90)	PA/TT T85 PA/A/TiCN/(0,90)		SQ 5*5
	(0,135)	PA/TT T85 PA/A		SQ 5*5
	(0,135)	PA/TT T85 PA/A/TiCN/(0,135)		RE 2*10
	(0,135)	PA/TT T85 PA/A/KPM/(0,135)		OB Φ3*10
	(0,135)	PA/TT T85 PA/A/(0,135)/Blanking		HX A=S=9.1-0.3
	3 Slots	PA/TT T85 PA/A/(0,45,90)		OB Φ3*10
	3 Slots	PA/TT T85 PA/A/TiCN/(0,45,90)		Class A FT/A*B
	4 Slots	PA/TT T85 PA/A/(0,90,180,270)		Class B FT/A*B
4 Slots	PA/TT T85 PA/A/TiCN/(0,90,180,270)		Class C FT/A*B	
1.1 Punch/Thick Turret 85 Punch				
	No Pin	Punch/TT 85 Punch/A		RO Φ5
	No Pin	Punch/TT 85 Punch/A/TiCN		RO Φ5
	No Pin	Punch/TT 85 Punch/A/KPM		RO Φ5
	Pin	Punch/TT 85 Punch/A		RE 2*10
	Pin	Punch/TT 85 Punch/A/TiCN		OB Φ3*10
	Pin	Punch/TT 85 Punch/A/KPM		SQ 5*5
1.2 Guide/Thick Turret 85 Guide				
	1 Slot	Guide/TT 85 Guide/A		RO Φ5
	(0,90)	Guide/TT 85 Guide/A		RE 2*10
	(0,135)	Guide/TT 85 Guide/A/Blanking		SQ 5*5-0.3
	3 Slots	Guide/TT 85 Guide/A/(0,45,90)		Class A FT/A*B
	4 Slots	Guide/TT 85 Guide/A/(0,90,180,270)		Class B FT/A*B
1.3 Punch Head Ass'y/Thick Turret T85 Punch Head Ass'y				
		PHA/TT T85 PHA/A		

T85 Light Duty		Slot/Pin	Description	Size(e.g.)
2# Punch Ass'y/Thick Turret T85 Light Duty Punch Ass'y				
	1 Slot	PA/TT T85 Light Duty PA/A		RO Φ5
	1 Slot	PA/TT T85 Light Duty PA/A/TiCN		RO Φ5
	1 Slot	PA/TT T85 Light Duty PA/A/KPM		RO Φ5
	(0,90)	PA/TT T85 Light Duty PA/A		RE 2*10
	(0,90)	PA/TT T85 Light Duty PA/A/TiCN		OB Φ3*10
	(0,90)	PA/TT T85 Light Duty PA/A/KPM		HX A=S=7.1
	(0,90)	PA/TT T85 Light Duty PA/A/TiCN/(0,90)		SQ 5*5
	(0,135)	PA/TT T85 Light Duty PA/A		SQ 5*5
	(0,135)	PA/TT T85 Light Duty PA/A/TiCN/(0,135)		RE 2*10
	(0,135)	PA/TT T85 Light Duty PA/A/KPM/(0,135)		OB Φ3*10
	(0,135)	PA/TT T85 Light Duty PA/A/(0,135)		HX A=S=9.1
	3 Slots	PA/TT T85 Light Duty PA/A/(0,45,90)		OB Φ3*10
	3 Slots	PA/TT T85 Light Duty PA/A/TiCN/(0,45,90)		Class A FT/A*B
	4 Slots	PA/TT T85 Light Duty PA/A/(0,90,180,270)		Class B FT/A*B
4 Slots	PA/TT T85 Light Duty PA/A/TiCN/(0,90,180,270)		Class C FT/A*B	
2.1 Punch/Thick Turret 85 Punch				
	No Pin	Punch/TT 85 Punch/A		RO Φ5
	No Pin	Punch/TT 85 Punch/A/TiCN		RO Φ5
	No Pin	Punch/TT 85 Punch/A/KPM		RO Φ5
	Pin	Punch/TT 85 Punch/A		RE 2*10
	Pin	Punch/TT 85 Punch/A/TiCN		OB Φ3*10
	Pin	Punch/TT 85 Punch/A/KPM		SQ 5*5
2.2 Guide/Thick Turret 85 Guide				
	1 Slot	Guide/TT 85 Guide/A		RO Φ5
	(0,90)	Guide/TT 85 Guide/A		RE 2*10
	(0,135)	Guide/TT 85 Guide/A		SQ 5*5
	3 Slots	Guide/TT 85 Guide/A/(0,45,90)		Class A FT/A*B
	4 Slots	Guide/TT 85 Guide/A/(0,90,180,270)		Class B FT/A*B
2.3 Punch Head Ass'y/Thick Turret T85 Light Duty Punch Head Ass'y				
		PHA/TT T85 Light Duty PHA/A		

*** PA: Punch Ass'y *** TT: Thick Turret *** TiCN: Coating *** PHA: Punch Head Ass'y *** KPM: KETEC Powder Material

A STN (Size Range:ΦD:1.0~12.7mm)

THICK TURRET
A STN

T85 Fully Guided A STN	Slot/Pin	Description	Size(e.g.)
------------------------	----------	-------------	------------

3# Punch Ass'y/Thick Turret T85 Fully Guided Punch Ass'y

	1 Slot	PA/TT T85 Fully Guided PA/A	RO Φ5
	1 Slot	PA/TT T85 Fully Guided PA/A/TiCN	RO Φ5
	1 Slot	PA/TT T85 Fully Guided PA/A/KPM	RO Φ5
	(0,90)	PA/TT T85 Fully Guided PA/A	RE 2*10
	(0,90)	PA/TT T85 Fully Guided PA/A/TiCN	OB Φ3*10
	(0,90)	PA/TT T85 Fully Guided PA/A/KPM	HX A=S=7.1
	(0,90)	PA/TT T85 Fully Guided PA/A/TiCN/(0,90)	SQ 5*5
	(0,135)	PA/TT T85 Fully Guided PA/A	SQ 5*5
	(0,135)	PA/TT T85 Fully Guided PA/A/TiCN/(0,135)	RE 2*10
	(0,135)	PA/TT T85 Fully Guided PA/A/KPM/(0,135)	OB Φ3*10
	(0,135)	PA/TT T85 Fully Guided PA/A/(0,135)	HX A=S=9.1
	3 Slots	PA/TT T85 Fully Guided PA/A/(0,45,90)	OB Φ3*10
	3 Slots	PA/TT T85 Fully Guided PA/A/TiCN/(0,45,90)	Class A FT/A*B
4 Slots	PA/TT T85 Fully Guided PA/A/(0,90,180,270)	Class B FT/A*B	
4 Slots	PA/TT T85 Fully Guided PA/A/TiCN/(0,90,180,270)	Class C FT/A*B	

3.1 Punch/TT 85 Fully Guided Punch

	No Pin	Punch/TT 85 Fully Guided Punch/A	RO Φ5
	No Pin	Punch/TT 85 Fully Guided Punch/A/TiCN	RO Φ5
	No Pin	Punch/TT 85 Fully Guided Punch/A/KPM	RO Φ5
	Pin	Punch/TT 85 Fully Guided Punch/A	RE 2*10
	Pin	Punch/TT 85 Fully Guided Punch/A/TiCN	OB Φ3*10
	Pin	Punch/TT 85 Fully Guided Punch/A/KPM	SQ 5*5

3.2 Guide/TT 85 Fully Guided Guide

	1 Slot	Guide/TT 85 Fully Guided Guide/A	RO Φ5
	(0,90)	Guide/TT 85 Fully Guided Guide/A	RE 2*10
	(0,135)	Guide/TT 85 Fully Guided Guide/A	SQ 5*5
	3 Slots	Guide/TT 85 Fully Guided Guide/A/(0,45,90)	Class A FT/A*B
	4 Slots	Guide/TT 85 Fully Guided Guide/A/(0,90,180,270)	Class B FT/A*B

3.3 Punch Head Ass'y/TT T85 Punch Head Ass'y

		PHA/TT T85 PHA/A	
--	--	------------------	--

T85 Fully Guided A STN	Slot/Pin	Description	Size(e.g.)
------------------------	----------	-------------	------------

4# Punch Ass'y/TT T85 Fully Guided Slitting Punch Ass'y

	1 Slot	PA/TT T85 Fully Guided PA/SPS/A	RO Φ1
	1 Slot	PA/TT T85 Fully Guided PA/SPS/A/TiCN	RO Φ2
	1 Slot	PA/TT T85 Fully Guided PA/SPS/A/KPM	RO Φ3
	1 Slot	PA/TT T85 Fully Guided PA/SPS/A	RO Φ4
	1 Slot	PA/TT T85 Fully Guided PA/SPS/A/TiCN	RO Φ5
	1 Slot	PA/TT T85 Fully Guided PA/SPS/A/KPM	RO Φ6

4.1 Punch/TT 85 Slitting Punch

	Pole Φ3.17/No Pin	Punch/TT 85 Slitting Punch/A	RO Φ1
	Pole Φ3.17/No Pin	Punch/TT 85 Slitting Punch/A/TiCN	RO Φ2
	Pole Φ3.17/No Pin	Punch/TT 85 Slitting Punch/A/KPM	RO Φ3
	Pole Φ6/No Pin	Punch/TT 85 Slitting Punch/A	RO Φ4
	Pole Φ6/No Pin	Punch/TT 85 Slitting Punch/A/TiCN	RO Φ5
	Pole Φ6/No Pin	Punch/TT 85 Slitting Punch/A/KPM	RO Φ6

4.2 Guide/TT 85 Fully Guided Guide

	1 Slot	Guide/TT 85 Fully Guided Guide/A	RO Φ1
	1 Slot	Guide/TT 85 Fully Guided Guide/A	RO Φ6



4.3 Punch Head Ass'y/TT T85 Punch Head Ass'y

		PHA/TT T85 PHA/A	
--	--	------------------	--

A STN (Size Range:ΦD:1.0~12.7mm)

THICK TURRET A STN



T85 Open Guide A STN	Slot/Pin	Description	Size(e.g.)	
5# Punch Ass'y/TT T85 Open Guide Punch Ass'y				
	1 Slot	PA/TT T85 Open Guide PA/A	RO Φ5	
	1 Slot	PA/TT T85 Open Guide PA/A/TiCN	RO Φ5	
	1 Slot	PA/TT T85 Open Guide PA/A/KPM	RO Φ5	
	(0,90)	PA/TT T85 Open Guide PA/A	RE 2*10	
	(0,90)	PA/TT T85 Open Guide PA/A/TiCN	OB Φ3*10	
	(0,90)	PA/TT T85 Open Guide PA/A/KPM	HX A=S=7.1	
	(0,90)	PA/TT T85 Open Guide PA/A/TiCN/(0,90)	SQ 5*5	
	(0,135)	PA/TT T85 Open Guide PA/A	SQ 5*5	
	(0,135)	PA/TT T85 Open Guide PA/A/TiCN/(0,135)	RE 2*10	
	(0,135)	PA/TT T85 Open Guide PA/A/KPM/(0,135)	OB Φ3*10	
	(0,135)	PA/TT T85 Open Guide PA/A/(0,135)	HX A=S=9.1	
	(0,90)	PA/TT T85 Open Guide PA/A/TiCN/Blanking	OB Φ3*10-0.3	

5.1 Punch/TT 85 Punch			
	No Pin	Punch/TT 85 Punch/A	RO Φ5
	No Pin	Punch/TT 85 Punch/A/TiCN	RO Φ5
	No Pin	Punch/TT 85 Punch/A/KPM	RO Φ5
	No Pin	Punch/TT 85 Punch/A	RE 2*10
	No Pin	Punch/TT 85 Punch/A/TiCN	OB Φ3*10
	No Pin	Punch/TT 85 Punch/A/Blanking	SQ 5*5-0.2

5.2 Guide/TT 85 Open Guide			
	1 Slot	Guide/TT 85 Open Guide/A/(0)	
	(0,90)	Guide/TT 85 Open Guide/A/(0,90)	
	(0,135)	Guide/TT 85 Open Guide/A/(0,135)	

5.3 Punch Head Ass'y/TT T85 Punch Head Ass'y		5.4 Stripper/TT 90 Stripper	
		PHA/TT T85 PHA/A	

T85 ABS A STN	Slot/Pin	Description	Size(e.g.)
6# Punch Ass'y/TT T85 ABS Punch Ass'y			
	1 Slot	PA/TT T85 ABS PA/A	RO Φ5
	1 Slot	PA/TT T85 ABS PA/A/TiCN	RO Φ5
	1 Slot	PA/TT T85 ABS PA/A/KPM	RO Φ5
	(0,90)	PA/TT T85 ABS PA/A	RE 2*10
	(0,90)	PA/TT T85 ABS PA/A/TiCN	OB Φ3*10
	(0,90)	PA/TT T85 ABS PA/A/KPM	HX A=S=7.1
	(0,90)	PA/TT T85 ABS PA/A/TiCN/(0,90)	SQ 5*5
	(0,135)	PA/TT T85 ABS PA/A	SQ 5*5
	(0,135)	PA/TT T85 ABS PA/A	RE 2*10
	(0,135)	PA/TT T85 ABS PA/A/KPM/(0,135)	OB Φ3*10
	(0,135)	PA/TT T85 ABS PA/A/(0,135)	HX A=S=9.1
	4 Slots	PA/TT T85 ABS PA/A/(0,90,180,270)	Class A FT/A*B
	4 Slots	PA/TT T85 ABS PA/A/TiCN/(0,90,180,270)	Class C FT/A*B
(0,135)	PA/TT T85 ABS PA/A/Blanking	SQ 5*5-0.2	

6.1 Punch/TT 85 ABS Punch			
	No Pin	Punch/TT 85 ABS Punch/A	RO Φ5
	No Pin	Punch/TT 85 ABS Punch/A/TiCN	RO Φ5
	No Pin	Punch/TT 85 ABS Punch/A/KPM	RO Φ5
	Pin	Punch/TT 85 ABS Punch/A	RE 2*10
	Pin	Punch/TT 85 ABS Punch/A/TiCN	OB Φ3*10
	Pin	Punch/TT 85 ABS Punch/A/KPM/Blanking	SQ 5*5-0.2

6.2 Guide/TT 85 ABS Guide			
	1 Slot	Guide/TT 85 ABS Guide/A	RO Φ5
	(0,90)	Guide/TT 85 ABS Guide/A	RE 2*10
	(0,135)	Guide/TT 85 ABS Guide/A	SQ 5*5
	4 Slots	Guide/TT 85 ABS Guide/A/(0,90,180,270)	Class B FT/A*B
	(0,135)	Guide/TT 85 ABS Guide/A/Blanking	SQ 5*5-0.2

6.3 Punch Ass'y/TT T85 Punch Ass'y			
		PHA/TT T85 PHA/A	

*** PA: Punch Ass'y *** TT: Thick Turret *** TiCN: Coating *** PHA: Punch Head Ass'y *** KPM: KETEC Powder Material

A STN (Size Range:ΦD:1.0~12.7mm)

THICK TURRET
A STN

T85 Open Guide ABS	Slot/Pin	Description	Size(e.g.)
--------------------	----------	-------------	------------

7# Punch Ass'y/TT T85 Open Guide ABS Punch Ass'y				
	1 Slot	PA/TT T85 Open Guide ABS PA/A	RO Φ5	
	1 Slot	PA/TT T85 Open Guide ABS PA/A/TiCN	RO Φ5	
	1 Slot	PA/TT T85 Open Guide ABS PA/A/KPM	RO Φ5	
	(0,90)	PA/TT T85 Open Guide ABS PA/A	RE 2*10	
	(0,90)	PA/TT T85 Open Guide ABS PA/A/TiCN	OB Φ3*10	
	(0,90)	PA/TT T85 Open Guide ABS PA/A/KPM	HX A=S=7.1	
	(0,90)	PA/TT T85 Open Guide ABS PA/A/TiCN/(0,90)	SQ 5*5	
	(0,135)	PA/TT T85 Open Guide ABS PA/A	SQ 5*5	
	(0,135)	PA/TT T85 Open Guide ABS PA/A/TiCN/(0,135)	RE 2*10	
	(0,135)	PA/TT T85 Open Guide ABS PA/A/KPM/(0,135)	OB Φ3*10	
	(0,135)	PA/TT T85 Open Guide ABS PA/A/(0,135)	HX A=S=9.1	

7.1 Punch/TT 85 ABS Punch			
	No Pin	Punch/TT 85 ABS Punch/A	RO Φ5
	No Pin	Punch/TT 85 ABS Punch/A/TiCN	RO Φ5
	No Pin	Punch/TT 85 ABS Punch/A/KPM	RO Φ5
	Pin	Punch/TT 85 ABS Punch/A	RE 2*10
	Pin	Punch/TT 85 ABS Punch/A/TiCN	OB Φ3*10
	Pin	Punch/TT 85 ABS Punch/A/KPM	SQ 5*5

7.2 Guide/TT85 ABS Open Guide			
	1 Slot	Guide/TT 85 Open Guide ABS/A/(0)	
	(0,90)	Guide/TT 85 Open Guide ABS/A/(0,90)	
	(0,135)	Guide/TT 85 Open Guide ABS/A/(0,135)	

7.3 Punch Head Ass'y/TT T85 Punch Head Ass'y		7.4 Stripper/Thick Turret 90 ABS Stripper	
		PHA/TT T85 PHA/A	
			Stripper/TT 90 ABS Stripper/A

T85 ABS Fully Guided	Slot/Pin	Description	Size(e.g.)
----------------------	----------	-------------	------------

8# Punch Ass'y/Thick Turret T85 ABS Fully Guided Punch Ass'y			
	1 Slot	PA/TT T85 ABS Fully Guided PA/A	RO Φ5
	1 Slot	PA/TT T85 ABS Fully Guided PA/A/TiCN	RO Φ5
	1 Slot	PA/TT T85 ABS Fully Guided PA/A/KPM	RO Φ5
	(0,90)	PA/TT T85 ABS Fully Guided PA/A	RE 2*10
	(0,90)	PA/TT T85 ABS Fully Guided PA/A/TiCN	OB Φ3*10
	(0,90)	PA/TT T85 ABS Fully Guided PA/A/KPM	HX A=S=7.1
	(0,90)	PA/TT T85 ABS Fully Guided PA/A/TiCN/(0,90)	SQ 5*5
	(0,135)	PA/TT T85 ABS Fully Guided PA/A	SQ 5*5
	(0,135)	PA/TT T85 ABS Fully Guided PA/A/TiCN/(0,135)	RE 2*10
	(0,135)	PA/TT T85 ABS Fully Guided PA/A/KPM/(0,135)	OB Φ3*10
	(0,135)	PA/TT T85 ABS Fully Guided PA/A/(0,135)	HX A=S=9.1
	3 Slots	PA/TT T85 ABS Fully Guided PA/A/(0,45,90)	OB Φ3*10
	3 Slots	PA/TT T85 ABS Fully Guided PA/A/TiCN/(0,45,90)	Class A FT/A*B
	4 Slots	PA/TT T85 ABS Fully Guided PA/A/(0,90,180,270)	Class B FT/A*B
	4 Slots	PA/TT T85 ABS Fully Guided PA/A/TiCN/(0,90,180,270)	Class C FT/A*B

8.1 Punch/TT 85 ABS Fully Guided Punch			
	No Pin	Punch/TT 85 ABS Fully Guided Punch/A	RO Φ5
	No Pin	Punch/TT 85 ABS Fully Guided Punch/A/TiCN	RO Φ5
	No Pin	Punch/TT 85 ABS Fully Guided Punch/A/KPM	RO Φ5
	Pin	Punch/TT 85 ABS Fully Guided Punch/A	RE 2*10
	Pin	Punch/TT 85 ABS Fully Guided Punch/A/TiCN	OB Φ3*10
	Pin	Punch/TT 85 ABS Fully Guided Punch/A/KPM	SQ 5*5

8.2 Guide/TT 85 ABS Fully Guided Guide			
	1 Slot	Guide/TT 85 ABS Fully Guided Guide/A	RO Φ5
	(0,90)	Guide/TT 85 ABS Fully Guided Guide/A	RE 2*10
	(0,135)	Guide/TT 85 ABS Fully Guided Guide/A	SQ 5*5
	3 Slots	Guide/TT 85 ABS Fully Guided Guide/A/(0,45,90)	Class A FT/A*B
	4 Slots	Guide/TT 85 ABS Fully Guided Guide/A/(0,90,180,270)	Class B FT/A*B

8.3 Punch Head Ass'y/TT T85 Punch Head Ass'y			
		PHA/TT T85 PHA/A	

A STN (Size Range: ΦD:1.0~12.7mm)

THICK TURRET A STN

T85 Light Duty A STN	Slot	Description	Size(e.g.)
----------------------	------	-------------	------------

9# Punch Ass'y/Thick Turret T85 Light Duty Fully Guided Punch Ass'y/Slitting Punch Ass'y



1 Slot	PA/TT T85 Light Duty Fully Guided Slitting PA/CP/A	RO Φ1
1 Slot	PA/TT T85 Light Duty Fully Guided Slitting PA/CP/A/TiCN	RO Φ2
1 Slot	PA/TT T85 Light Duty Fully Guided Slitting PA/CP/A/KPM	RO Φ3
1 Slot	PA/TT T85 Light Duty Fully Guided Slitting PA/CP/A	RO Φ4
1 Slot	PA/TT T85 Light Duty Fully Guided Slitting PA/CP/A/TiCN	RO Φ5
1 Slot	PA/TT T85 Light Duty Fully Guided Slitting PA/CP/A/KPM	RO Φ6

9.1 Punch/Thick Turret 85 Slitting Punch



Pole Φ3.17/No Pin	Punch/TT 85 Slitting Punch/A	RO Φ1
Pole Φ3.17/No Pin	Punch/TT 85 Slitting Punch/A/TiCN	RO Φ2
Pole Φ3.17/No Pin	Punch/TT 85 Slitting Punch/A/KPM	RO Φ3
Pole Φ6/No Pin	Punch/TT 85 Slitting Punch/A	RO Φ4
Pole Φ6/No Pin	Punch/TT 85 Slitting Punch/A/TiCN	RO Φ5
Pole Φ6/No Pin	Punch/TT 85 Slitting Punch/A/KPM	RO Φ6

9.2 Guide/TT 85 Fully Guided Guide



1 Slot	Guide/TT 85 Fully Guided Guide/A	RO Φ1
1 Slot	Guide/TT 85 Fully Guided Guide/A	RO Φ6

9.3 Punch Head Ass'y/Thick Turret T85 Light Duty Punch Head Ass'y



	PHA/TT T85 Light Duty PHA/A	
--	-----------------------------	--

T85 ABS Fully Guided	Slot/Pin	Description	Size(e.g.)
----------------------	----------	-------------	------------

10# Punch Ass'y/Thick Turret T85 ABS Fully Guided Punch Ass'y/Slitting Punch Ass'y



1 Slot	PA/TT T85 ABS Fully Guided Slitting PA/CA/A	RO Φ1
1 Slot	PA/TT T85 ABS Fully Guided Slitting PA/CA/A/TiCN	RO Φ2
1 Slot	PA/TT T85 ABS Fully Guided Slitting PA/CA/A/KPM	RO Φ3
1 Slot	PA/TT T85 ABS Fully Guided Slitting PA/CA/A	RO Φ4
1 Slot	PA/TT T85 ABS Fully Guided Slitting PA/CA/A/TiCN	RO Φ5
1 Slot	PA/TT T85 ABS Fully Guided Slitting PA/CA/A/KPM	RO Φ6

10.1 Punch/Thick Turret 85 ABS Slitting Punch

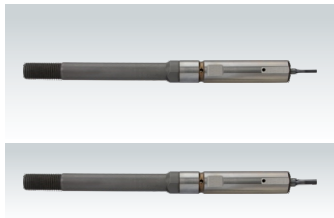

Pole Φ4/No Pin	Punch/TT 85 ABS Slitting Punch/A	RO Φ1
Pole Φ4/No Pin	Punch/TT 85 ABS Slitting Punch/A/TiCN	RO Φ2
Pole Φ4/No Pin	Punch/TT 85 ABS Slitting Punch/A/KPM	RO Φ3
Pole Φ4/No Pin	Punch/TT 85 ABS Slitting Punch/A/Alloys	RO Φ2
Pole Φ4/No Pin	Punch/TT 85 ABS Slitting Punch/A/Alloys	RO Φ2.5
Pole Φ6/No Pin	Punch/TT 85 ABS Slitting Punch/A	RO Φ4
Pole Φ6/No Pin	Punch/TT 85 ABS Slitting Punch/A/TiCN	RO Φ5
Pole Φ6/No Pin	Punch/TT 85 ABS Slitting Punch/A/KPM	RO Φ6

10.2 Guide/Thick Turret 85 ABS Fully Guided Guide

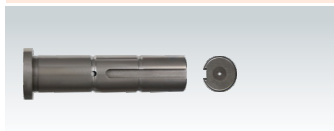

1 Slot	Guide/TT 85 ABS Fully Guided Guide/A	RO Φ1
1 Slot	Guide/TT 85 ABS Fully Guided Guide/A	RO Φ6

10.3 Punch Head Ass'y/Thick Turret T85 Punch Head Ass'y



	Punch Head Ass'y/Thick Turret T85Punch Head Ass'y/A	
--	---	--

*** PA: Punch Ass'y *** TT: Thick Turret *** TiCN: Coating *** PHA: Punch Head Ass'y *** KPM: KETEC Powder Material

A STN (Size Range:ΦD:1.0~12.7mm)

THICK TURRET A STN

T90 A STN	Slot/Pin	Description	Size (e.g.)
-----------	----------	-------------	-------------

11# Punch Ass'y/Thick Turret T90 Punch Ass'y			
	1 Slot	PA/TT T90 PA/A	RO Φ5
	1 Slot	PA/TT T90 PA/A/TiCN	RO Φ5
	1 Slot	PA/TT T90 PA/A/KPM	RO Φ5
	(0,90)	PA/TT T90 PA/A	RE 2*10
	(0,90)	PA/TT T90 PA/A/TiCN	OB Φ3*10
	(0,90)	PA/TT T90 PA/A/KPM	HX A=S=7.1
	(0,90)	PA/TT T90 PA/A/TiCN/(0,90)	SQ 5*5
	(0,135)	PA/TT T90 PA/A/Blanking	SQ 5*5-0.2
	(0,135)	PA/TT T90 PA/A/TiCN/(0,135)	RE 2*10
	(0,135)	PA/TT T90 PA/A/KPM/(0,135)	OB Φ3*10
	(0,135)	PA/TT T90 PA/A/(0,135)	HX A=S=9.1
	3 Slots	PA/TT T90 PA/A/(0,45,90)	OB Φ3*10
	3 Slots	PA/TT T90 PA/A/TiCN/(0,45,90)	Class A FT/A*B
	4 Slots	PA/TT T90 PA/A/(0,90,180,270)	Class B FT/A*B
4 Slots	PA/TT T90 PA/A/TiCN/(0,90,180,270)	Class C FT/A*B	

11.1 Punch/Thick Turret 90 Punch			
	No Pin	Punch/TT 90 Punch/A	RO Φ5
	No Pin	Punch/TT 90 Punch/A/TiCN	RO Φ5
	No Pin	Punch/TT 90 Punch/A/KPM	RO Φ5
	Pin	Punch/TT 90 Punch/A	RE 2*10
	Pin	Punch/TT 90 Punch/A/TiCN	OB Φ3*10
	Pin	Punch/TT 90 Punch/A/KPM/Blanking	SQ 5*5-0.2

11.2 Guide/Thick Turret 90 Guide			
	1 Slot	Guide/TT 90 Guide/A/(0)	
	(0,90)	Guide/TT 90 Guide/A/(0,90)	
	(0,135)	Guide/TT 90 Guide/A/(0,135)	
	3 Slots	Guide/TT 90 Guide/A/(0,45,90)	
	4 Slots	Guide/TT 90 Guide/A/(0,90,180,270)	

11.3 Punch Head Ass'y/Thick Turret T90 Punch Head Ass'y		11.4 Stripper/Thick Turret 90 Stripper	
		PHA/TT T90 PHA/A	
			Stripper/TT 90 Stripper/A
			Stripper/TT 90 Stripper/A/Blank

T90 ABS A STN	Slot/Pin	Description	Size (e.g.)
---------------	----------	-------------	-------------

12# Punch Ass'y/Thick Turret T90 ABS Punch Ass'y			
	1 Slot	PA/TT T90 ABS PA/A	RO Φ5
	1 Slot	PA/TT T90 ABS PA/A/TiCN	RO Φ5
	1 Slot	PA/TT T90 ABS PA/A/KPM	RO Φ5
	(0,90)	PA/TT T90 ABS PA/A	RE 2*10
	(0,90)	PA/TT T90 ABS PA/A/TiCN	OB Φ3*10
	(0,90)	PA/TT T90 ABS PA/A/KPM	HX A=S=7.1
	(0,90)	PA/TT T90 ABS PA/A/TiCN/(0,90)	SQ 5*5
	(0,135)	PA/TT T90 ABS PA/A	SQ 5*5
	(0,135)	PA/TT T90 ABS PA/A/TiCN/(0,135)	RE 2*10
	(0,135)	PA/TT T90 ABS PA/A/KPM/(0,135)	OB Φ3*10
	(0,135)	PA/TT T90 ABS PA/A/(0,135)	HX A=S=9.1
	3 Slots	PA/TT T90 ABS PA/A/(0,45,90)	OB Φ3*10
	3 Slots	PA/TT T90 ABS PA/A/TiCN/(0,45,90)	Class A FT/A*B
	4 Slots	PA/TT T90 ABS PA/A/(0,90,180,270)	Class B FT/A*B
4 Slots	PA/TT T90 ABS PA/A/TiCN/(0,90,180,270)	Class C FT/A*B	

12.1 Punch/Thick Turret 90 ABS Punch			
	No Pin	Punch/TT 90 ABS Punch/A	RO Φ5
	No Pin	Punch/TT 90 ABS Punch/A/TiCN	RO Φ5
	No Pin	Punch/TT 90 ABS Punch/A/KPM	RO Φ5
	Pin	Punch/TT 90 ABS Punch/A	RE 2*10
	Pin	Punch/TT 90 ABS Punch/A/TiCN	OB Φ3*10
	Pin	Punch/TT 90 ABS Punch/A/KPM	SQ 5*5

12.2 Guide/Thick Turret 90 ABS Guide			
	1 Slot	Guide/TT 90 ABS Guide/A/(0)	
	(0,90)	Guide/TT 90 ABS Guide/A/(0,90)	
	(0,135)	Guide/TT 90 ABS Guide/A/(0,135)	
	3 Slots	Guide/TT 90 ABS Guide/A/(0,45,90)	
	4 Slots	Guide/TT 90 ABS Guide/A/(0,90,180,270)	



12.3 Punch Head Ass'y/Thick Turret T90 Punch Head Ass'y		12.4 Stripper/Thick Turret 90 ABS Stripper	
		PHA/TT T90 PHA/A	
			Stripper/TT 90 ABS Stripper/A

A STN (Size Range:ΦD:1.0~12.7mm)



THICK TURRET A STN

T90 Heavy Duty A STN	Slot	Description	Size(e.g.)
----------------------	------	-------------	------------

13# Punch Ass'y/Thick Turret T90 Heavy Duty Punch Ass'y			
	1 Slot	PA/TT T90 Heavy Duty PA/A	RO Φ5
	1 Slot	PA/TT T90 Heavy Duty PA/A/TiCN	RO Φ5
	1 Slot	PA/TT T90 Heavy Duty PA/A/KPM	RO Φ5
	(0,90)	PA/TT T90 Heavy Duty PA/A	RE 2*10
	(0,90)	PA/TT T90 Heavy Duty PA/A/TiCN	OB Φ3*10
	(0,90)	PA/TT T90 Heavy Duty PA/A/KPM	HX A=S=7.1
	(0,90)	PA/TT T90 Heavy Duty PA/A/TiCN/(0,90)	SQ 5*5
	(0,135)	PA/TT T90 Heavy Duty PA/A	SQ 5*5
	(0,135)	PA/TT T90 Heavy Duty PA/A/TiCN/(0,135)	RE 2*10
	(0,135)	PA/TT T90 Heavy Duty PA/A/KPM/(0,135)	OB Φ3*10
	(0,135)	PA/TT T90 Heavy Duty PA/A/(0,135)	HX A=S=9.1
	3 Slots	PA/TT T90 Heavy Duty PA/A/(0,45,90)	OB Φ3*10
	3 Slots	PA/TT T90 Heavy Duty PA/A/TiCN/(0,45,90)	Class A FT/A*B
	4 Slots	PA/TT T90 Heavy Duty PA/A/(0,90,180,270)	Class B FT/A*B
	4 Slots	PA/TT T90 Heavy Duty PA/A/TiCN/(0,90,180,270)	Class C FT/A*B



13.1 Punch/Thick Turret 90 Heavy Duty Punch			
	No Pin	Punch/TT 90 Heavy Duty Punch/A	RO Φ5
	No Pin	Punch/TT 90 Heavy Duty Punch/A/TiCN	RO Φ5
	No Pin	Punch/TT 90 Heavy Duty Punch/A/KPM	RO Φ5
	Pin	Punch/TT 90 Heavy Duty Punch/A	RE 2*10
	Pin	Punch/TT 90 Heavy Duty Punch/A/TiCN	OB Φ3*10
	Pin	Punch/TT 90 Heavy Duty Punch/A/KPM	SQ 5*5

13.2 Guide/Thick Turret 90 Guide			
	1 Slot	Guide/TT 90 Guide/A/(0)	
	(0,90)	Guide/TT 90 Guide/A/(0,90)	
	(0,135)	Guide/TT 90 Guide/A/(0,135)	
	3 Slots	Guide/TT 90 Guide/A/(0,45,90)	
	4 Slots	Guide/TT 90 Guide/A/(0,90,180,270)	

13.3 Punch Head Ass'y/Thick Turret T90 Heavy Duty Punch Head Ass'y		13.4 Stripper/Thick Turret 90 Stripper	
		PHA/TT T90 Heavy Duty PHA/A	

E85 A STN	Slot/Pin	Description	Size(e.g.)
-----------	----------	-------------	------------

14# Punch Ass'y/Thick Turret E85 Punch Ass'y			
	1 Slot	PA/TT E85 PA/A	RO Φ5
	1 Slot	PA/TT E85 PA/A/TiCN	RO Φ5
	1 Slot	PA/TT E85 PA/A/KPM	RO Φ5
	(0,90)	PA/TT E85 PA/A	RE 2*10
	(0,90)	PA/TT E85 PA/A/TiCN/Blanking	OB Φ3*10-0.3
	(0,90)	PA/TT E85 PA/A/KPM	HX A=S=7.1
	(0,90)	PA/TT E85 PA/A/TiCN/(0,90)	SQ 5*5
	(0,135)	PA/TT E85 PA/A	SQ 5*5
	(0,135)	PA/TT E85 PA/A/TiCN/(0,135)	RE 2*10
	(0,135)	PA/TT E85 PA/A/KPM/(0,135)	OB Φ3*10
	(0,135)	PA/TT E85 PA/A/(0,135)	HX A=S=9.1
	3 Slots	PA/TT E85 PA/A/(0,45,90)	OB Φ3*10
	3 Slots	PA/TT E85 PA/A/TiCN/(0,45,90)	Class A FT/A*B
	4 Slots	PA/TT E85 PA/A/(0,90,180,270)	Class B FT/A*B
	4 Slots	PA/TT E85 PA/A/TiCN/(0,90,180,270)	Class C FT/A*B

14.1 Punch/Thick Turret 85 Punch			
	No Pin	Punch/TT 85 Punch/A	RO Φ5
	No Pin	Punch/TT 85 Punch/A/TiCN	RO Φ5
	No Pin	Punch/TT 85 Punch/A/KPM	RO Φ5
	Pin	Punch/TT 85 Punch/A	RE 2*10
	Pin	Punch/TT 85 Punch/A/TiCN	OB Φ3*10
	Pin	Punch/TT 85 Punch/A/KPM	SQ 5*5

14.2 Guide/Thick Turret 85 Guide			
	1 Slot	Guide/TT 85 Guide/A	RO Φ5
	(0,90)	Guide/TT 85 Guide/A	RE 2*10
	(0,135)	Guide/TT 85 Guide/A	SQ 5*5
	3 Slots	Guide/TT 85 Guide/A/(0,45,90)/Blanking	SQ 5*5-0.2
	4 Slots	Guide/TT 85 Guide/A/(0,90,180,270)	Class B FT/A*B

14.3 Punch Head Ass'y/Thick Turret E85 Punch Head Ass'y			
		PHA/TT E85 PHA/A	

*** PA: Punch Ass'y *** TT: Thick Turret *** TiCN: Coating *** PHA: Punch Head Ass'y *** KPM: KETEC Powder Material

A STN (Size Range:ΦD:1.0~12.7mm)

THICK TURRET A STN

E85 Light Duty A STN	Slot/Pin	Description	Size (e.g.)
----------------------	----------	-------------	-------------

15# Punch Ass'y/Thick Turret E85 Light Duty Punch Ass'y			
	1 Slot	PA/TT E85 Light Duty PA/A	RO Φ5
	1 Slot	PA/TT E85 Light Duty PA/A/TiCN	RO Φ5
	1 Slot	PA/TT E85 Light Duty PA/A/KPM	RO Φ5
	(0,90)	PA/TT E85 Light Duty PA/A	RE 2*10
	(0,90)	PA/TT E85 Light Duty PA/A	OB Φ3*10
	(0,90)	PA/TT E85 Light Duty PA/A/KPM	HX A=S=7.1
	(0,90)	PA/TT E85 Light Duty PA/A/TiCN/(0,90)	SQ 5*5
	(0,135)	PA/TT E85 Light Duty PA/A	SQ 5*5
	(0,135)	PA/TT E85 Light Duty PA/A/TiCN/(0,135)	RE 2*10
	(0,135)	PA/TT E85 Light Duty PA/A/KPM/(0,135)	OB Φ3*10
	(0,135)	PA/TT E85 Light Duty PA/A/(0,135)	HX A=S=9.1
	3 Slots	PA/TT E85 Light Duty PA/A/(0,45,90)	OB Φ3*10
	3 Slots	PA/TT E85 Light Duty PA/A/TiCN/(0,45,90)	Class A FT/A*B
4 Slots	PA/TT E85 Light Duty PA/A/(0,90,180,270)	Class B FT/A*B	
4 Slots	PA/TT E85 Light Duty PA/A/TiCN/(0,90,180,270)	Class C FT/A*B	

15.1 Punch/Thick Turret 85 Punch			
	No Pin	Punch/TT 85 Punch/A	RO Φ5
	No Pin	Punch/TT 85 Punch/A/TiCN	RO Φ5
	No Pin	Punch/TT 85 Punch/A/KPM	RO Φ5
	Pin	Punch/TT 85 Punch/A	RE 2*10
	Pin	Punch/TT 85 Punch/A/TiCN	OB Φ3*10
	Pin	Punch/TT 85 Punch/A/KPM	SQ 5*5

15.2 Guide/Thick Turret 85 Guide			
	1 Slot	Guide/TT 85 Guide/A	RO Φ5
	(0,90)	Guide/TT 85 Guide/A	RE 2*10
	(0,135)	Guide/TT 85 Guide/A	SQ 5*5
	3 Slots	Guide/TT 85 Guide/A/(0,45,90)	Class A FT/A*B
	4 Slots	Guide/TT 85 Guide/A/(0,90,180,270)	Class B FT/A*B

15.3 Punch Head Ass'y/Thick Turret 85 Light Duty Punch Head Ass'y			
		PHA/TT E85 Light Duty PHA/A	

E80 A STN	Slot/Pin	Description	Size (e.g.)
-----------	----------	-------------	-------------

16# Punch Ass'y/Thick Turret E80 Punch Ass'y			
	1 Slot	PA/TT E80 PA/A	RO Φ5
	1 Slot	PA/TT E80 PA/A/TiCN	RO Φ5
	1 Slot	PA/TT E80 PA/A/KPM	RO Φ5
	(0,90)	PA/TT E80 PA/A	RE 2*10
	(0,90)	PA/TT E80 PA/A	OB Φ3*10
	(0,90)	PA/TT E80 PA/A	HX A=S=7.1
	(0,90)	PA/TT E80 PA/A	SQ 5*5
	(0,135)	PA/TT E80 PA/A	SQ 5*5
	(0,135)	PA/TT E80 PA/A/TiCN/(0,135)	RE 2*10
	(0,135)	PA/TT E80 PA/A/KPM/(0,135)	OB Φ3*10
	(0,135)	PA/TT E80 PA/A/(0,135)	HX A=S=9.1
	3 Slots	PA/TT E80 PA/A/(0,45,90)	OB Φ3*10
	3 Slots	PA/TT E80 PA/A/TiCN/(0,45,90)	Class A FT/A*B
4 Slots	PA/TT E80 PA/A/(0,90,180,270)	Class B FT/A*B	
4 Slots	PA/TT E80 PA/A/TiCN/(0,90,180,270)	Class C FT/A*B	

16.1 Punch/Thick Turret 80 Punch			
	No Pin	Punch/TT 80 Punch/A	RO Φ5
	No Pin	Punch/TT 80 Punch/A/TiCN	RO Φ5
	No Pin	Punch/TT 80 Punch/A/KPM	RO Φ5
	Pin	Punch/TT 80 Punch/A	RE 2*10
	Pin	Punch/TT 80 Punch/A/TiCN	OB Φ3*10
	Pin	Punch/TT 80 Punch/A/KPM	SQ 5*5

16.2 Guide/Thick Turret 90 Guide			
	1 Slot	Guide/TT 90 Guide/A/(0)	
	(0,90)	Guide/TT 90 Guide/A/(0,90)	
	(0,135)	Guide/TT 90 Guide/A/(0,135)	
	3 Slots	Guide/TT 90 Guide/A/(0,45,90)	
	4 Slots	Guide/TT 90 Guide/A/(0,90,180,270)	

16.2 Punch Head Ass'y/Thick Turret E80 Punch Head Ass'y		16.4 Stripper/Thick Turret 90 Stripper	
	PHA/TT E80 PHA/A		Stripper/TT 90 Stripper/A

A STN (Size Range:ΦD:1.0~12.7mm)



THICK TURRET A STN

E80 Heavy Duty A STN	Slot/Pin	Description	Size(e.g.)
----------------------	----------	-------------	------------

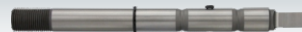
17# Punch Ass'y/Thick Turret E80 Heavy Duty Punch Ass'y			
	1 Slot	PA/TT E80 Heavy Duty PA/A	RO Φ5
	1 Slot	PA/TT E80 Heavy Duty PA/A/TiCN	RO Φ5
	1 Slot	PA/TT E80 Heavy Duty PA/A/KPM	RO Φ5
	(0,90)	PA/TT E80 Heavy Duty PA/A	RE 2*10
	(0,90)	PA/TT E80 Heavy Duty PA/A/TiCN	OB Φ3*10
	(0,90)	PA/TT E80 Heavy Duty PA/A/KPM	HX A=S=7.1
	(0,90)	PA/TT E80 Heavy Duty PA/A/TiCN/(0,90)	SQ 5*5
	(0,135)	PA/TT E80 Heavy Duty PA/A	SQ 5*5
	(0,135)	PA/TT E80 Heavy Duty PA/A/TiCN/(0,135)	RE 2*10
	(0,135)	PA/TT E80 Heavy Duty PA/A/KPM/(0,135)	OB Φ3*10
	(0,135)	PA/TT E80 Heavy Duty PA/A/(0,135)	HX A=S=9.1
	3 Slots	PA/TT E80 Heavy Duty PA/A/(0,45,90)	OB Φ3*10
	3 Slots	PA/TT E80 Heavy Duty PA/A/TiCN/(0,45,90)	Class A FT/A*B
	4 Slots	PA/TT E80 Heavy Duty PA/A/(0,90,180,270)	Class B FT/A*B
4 Slots	PA/TT E80 Heavy Duty PA/A/TiCN/(0,90,180,270)	Class C FT/A*B	



17.1 Punch/Thick Turret 80 Heavy Duty Punch			
	No Pin	Punch/TT 80 Heavy Duty Punch/A	RO Φ5
	No Pin	Punch/TT 80 Heavy Duty Punch/A/TiCN	RO Φ5
	No Pin	Punch/TT 80 Heavy Duty Punch/A/KPM	RO Φ5
	Pin	Punch/TT 80 Heavy Duty Punch/A	RE 2*10
	Pin	Punch/TT 80 Heavy Duty Punch/A/TiCN	OB Φ3*10
	Pin	Punch/TT 80 Heavy Duty Punch/A/KPM	SQ 5*5

17.2 Guide/Thick Turret 90 Guide			
	1 Slot	Guide/TT 90 Guide/A/(0)	
	(0,90)	Guide/TT 90 Guide/A/(0,90)	
	(0,135)	Guide/TT 90 Guide/A/(0,135)	
	3 Slots	Guide/TT 90 Guide/A/(0,45,90)	
	4 Slots	Guide/TT 90 Guide/A/(0,90,180,270)	



17.3 Punch Head Ass'y/Thick Turret E80 Heavy Duty Punch Head Ass'y		17.4 Stripper/Thick Turret 90 Stripper	
		PHA/TT E80 Heavy Duty PHA/A	

E80 Heavy Duty SH	Slot/Pin	Description	Size(e.g.)
-------------------	----------	-------------	------------

18# Punch Ass'y/Thick Turret E80 Heavy Duty Special Height Punch Ass'y			
	1 Slot	PA/TT E80 Heavy Duty SH PA/A	RO Φ5
	1 Slot	PA/TT E80 Heavy Duty SH PA/A/TiCN	RO Φ5
	1 Slot	PA/TT E80 Heavy Duty SH PA/A/KPM	RO Φ5
	(0,90)	PA/TT E80 Heavy Duty SH PA/A	RE 2*10
	(0,90)	PA/TT E80 Heavy Duty SH PA/A/TiCN	OB Φ3*10
	(0,90)	PA/TT E80 Heavy Duty SH PA/A/KPM	HX A=S=7.1
	(0,90)	PA/TT E80 Heavy Duty SH PA/A/TiCN/(0,90)	SQ 5*5
	(0,135)	PA/TT E80 Heavy Duty SH PA/A	SQ 5*5
	(0,135)	PA/TT E80 Heavy Duty SH PA/A/TiCN/(0,135)	RE 2*10
	(0,135)	PA/TT E80 Heavy Duty SH PA/A/KPM/(0,135)	OB Φ3*10
	(0,135)	PA/TT E80 Heavy Duty SH PA/A/(0,135)	HX A=S=9.1
	3 Slots	PA/TT E80 Heavy Duty SH PA/A/(0,45,90)	OB Φ3*10
	3 Slots	PA/TT E80 Heavy Duty SH PA/A/TiCN/(0,45,90)	Class A FT/A*B
	4 Slots	PA/TT E80 Heavy Duty SH PA/A/(0,90,180,270)	Class B FT/A*B
4 Slots	PA/TT E80 Heavy Duty SH PA/A/TiCN/(0,90,180,270)	Class C FT/A*B	

18.1 Punch/Thick Turret 80 Heavy Duty Punch			
	No Pin	Punch/TT 80 Heavy Duty Punch/A	RO Φ5
	No Pin	Punch/TT 80 Heavy Duty Punch/A/TiCN	RO Φ5
	No Pin	Punch/TT 80 Heavy Duty Punch/A/KPM	RO Φ5
	Pin	Punch/TT 80 Heavy Duty Punch/A	RE 2*10
	Pin	Punch/TT 80 Heavy Duty Punch/A/TiCN	OB Φ3*10
	Pin	Punch/TT 80 Heavy Duty Punch/A/KPM	SQ 5*5

18.2 Guide/Thick Turret 90 Guide			
	1 Slot	Guide/TT 90 Guide/A/(0)	
	(0,90)	Guide/TT 90 Guide/A/(0,90)	
	(0,135)	Guide/TT 90 Guide/A/(0,135)	
	3 Slots	Guide/TT 90 Guide/A/(0,45,90)	
	4 Slots	Guide/TT 90 Guide/A/(0,90,180,270)	

18.3 Punch Head Ass'y/Thick Turret E80 Heavy Duty Special Height Punch Head Ass'y		18.4 Stripper/Thick Turret 90 Stripper	
		PHA/TT E80 Heavy Duty SH PHA/A	

*** PA: Punch Ass'y *** TT: Thick Turret *** TiCN: Coating *** PHA: Punch Head Ass'y *** KPM: KETEC Powder Material
 *** SH: Special Height

A STN (Size Range:ΦD:1.0~12.7mm)

THICK TURRET A STN

KU A STN	Slot	Description	Size (e.g.)
19# Punch Ass'y/Thick Turret KU Punch Ass'y			
	1 Slot	PA/TT KU PA/A	RO Φ5
	1 Slot	PA/TT KU PA/A/TiCN	RO Φ5
	1 Slot	PA/TT KU PA/A/KPM	RO Φ5
	(0,90)	PA/TT KU PA/A	RE 2*10
	(0,90)	PA/TT KU PA/A/TiCN	OB Φ3*10
	(0,90)	PA/TT KU PA/A/KPM	HX A=S=7.1
	(0,90)	PA/TT KU PA/A/TiCN/(0,90)	SQ 5*5
	(0,135)	PA/TT KU PA/A	SQ 5*5
	(0,135)	PA/TT KU PA/A/TiCN/(0,135)	RE 2*10
	(0,135)	PA/TT KU PA/A/KPM/(0,135)	OB Φ3*10
(0,135)	PA/TT KU PA/A/(0,135)	HX A=S=9.1	
(0,135)	PA/TT KU PA/A/(0,135)/Blanking	HX A=S=9.1-0.2	
19.1 Punch/Thick Turret KU Punch			
	Pin	Punch/TT KU Punch/A	RO Φ5
	Pin	Punch/TT KU Punch/A/TiCN	RO Φ5
	Pin	Punch/TT KU Punch/A/KPM	RO Φ5
	Pin	Punch/TT KU Punch/A	RE 2*10
	Pin	Punch/TT KU Punch/A/TiCN	OB Φ3*10
	Pin	Punch/TT KU Punch/A/KPM	SQ 5*5
	Pin	Punch/TT KU Punch/A/Blanking	SQ 5*5-0.2
19.2 Guide/Thick Turret KU Guide			
	1 Slot	Guide/TT KU Guide/A/(0)	
	(0,90)	Guide/TT KU Guide/A/(0,90)	
	(0,135)	Guide/TT KU Guide/A/(0,135)	
19.3 Punch Head Ass'y/Thick Turret KU Punch Head Ass'y		19.4 Stripper/Thick Turret KU Stripper	
		PHA/TT KU PHA/A	
		Stripper/TT KU Stripper/A	
		Stripper/TT KU S/A/Blanking	

*** KPM: Ketec Powder Material

*** TT: Thick Turret

*** PHA: Punch Head Ass'y

*** TiCN: Coating

STANDARD SHAPE

Angle: Vertical View of work.
Anti-clockwise for 0 to 90 degree.

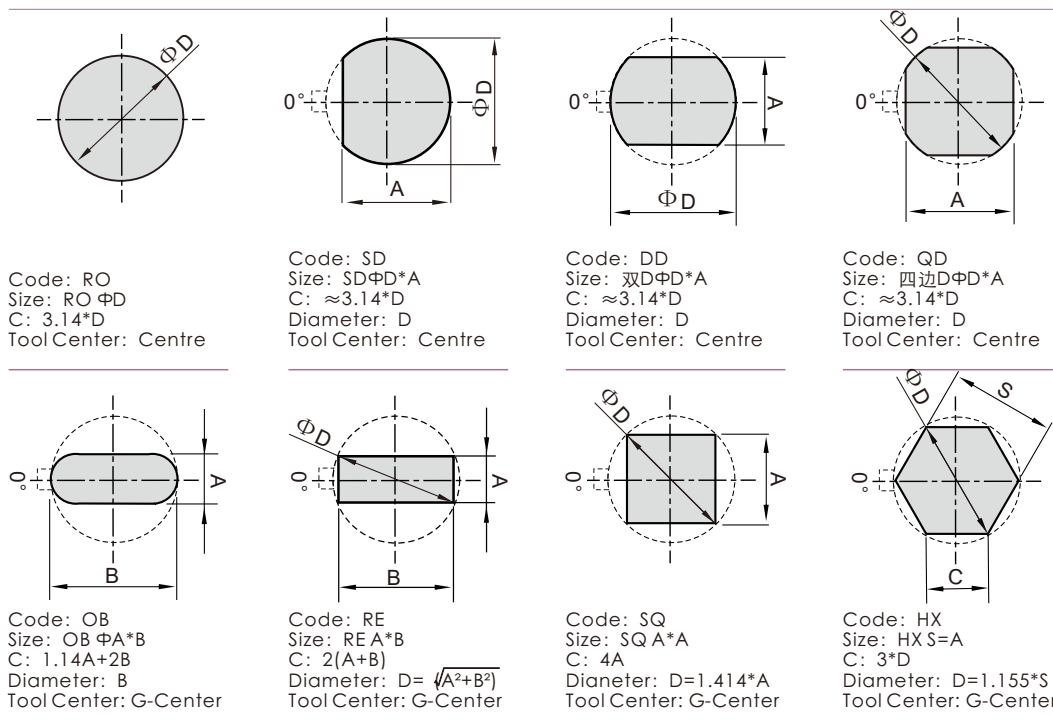

A STN (Size Range:ΦD:1.0~12.7mm)

85 Punch	Slot	Description	Size(e.g.)
1# Punch/Thick Turret 85 Punch			
	No Pin	Punch/TT 85 Punch/A	RO Φ5
	No Pin	Punch/TT 85 Punch/A/TiCN	RO Φ5
	No Pin	Punch/TT 85 Punch/A/KPM	RO Φ5
	Pin	Punch/TT 85 Punch/A	RE 2*10
	Pin	Punch/TT 85 Punch/A/TiCN	OB Φ3*10
	Pin	Punch/TT 85 Punch/A/Blanking	SQ 5*5-0.2
2# Punch/Thick Turret 85 ABS Punch			
	No Pin	Punch/TT 85 ABS Punch/A	RO Φ5
	No Pin	Punch/TT 85 ABS Punch/A/TiCN	RO Φ5
	No Pin	Punch/TT 85 ABS Punch/A/Blanking	RO Φ5-0.2
	Pin	Punch/TT 85 ABS Punch/A	RE 2*10
	Pin	Punch/TT 85 ABS Punch/A/TiCN	OB Φ3*10
	Pin	Punch/TT 85 ABS Punch/A/KPM	SQ 5*5
3# Punch/Thick Turret 85 Fully Guided Punch			
	No Pin	Punch/TT 85 Fully Guided Punch/A	RO Φ5
	No Pin	Punch/TT 85 Fully Guided Punch/A/TiCN	RO Φ5
	No Pin	Punch/TT 85 Fully Guided Punch/A/KPM	RO Φ5
	Pin	Punch/TT 85 Fully Guided Punch/A	RE 2*10
	Pin	Punch/TT 85 Fully Guided Punch/A/TiCN	OB Φ3*10
	Pin	Punch/TT 85 Fully Guided Punch/A/KPM	SQ 5*5
4# Punch/Thick Turret 85 ABS Fully Guided Punch			
	No Pin	Punch/TT 85 ABS Fully Guided Punch/A	RO Φ5
	No Pin	Punch/TT 85 ABS Fully Guided Punch/A/TiCN	RO Φ5
	No Pin	Punch/TT 85 ABS Fully Guided Punch/A/KPM	RO Φ5
	Pin	Punch/TT 85 ABS Fully Guided Punch/A	RE 2*10
	Pin	Punch/TT 85 ABS Fully Guided Punch/A/TiCN	OB Φ3*10
	Pin	Punch/TT 85 ABS Fully Guided Punch/A/KPM	SQ 5*5
5# Punch/Thick Turret 85 Slitting Punch			
	Pole Φ3.17/No Pin	Punch/TT 85 Slitting Punch/A	RO Φ2
	Pole Φ3.17/No Pin	Punch/TT 85 Slitting Punch/A/TiCN	RO Φ2
	Pole Φ3.17/No Pin	Punch/TT 85 Slitting Punch/A/KPM	RO Φ2
	Pole Φ6/No Pin	Punch/TT 85 Slitting Punch/A	RO Φ5
	Pole Φ6/No Pin	Punch/TT 85 Slitting Punch/A/TiCN	RO Φ5
	Pole Φ6/No Pin	Punch/TT 85 Slitting Punch/A/KPM	RO Φ5
6# Punch/Thick Turret 85 ABS Slitting Punch			
	Pole Φ4/No Pin	Punch/TT 85 ABS Slitting Punch/A	RO Φ1
	Pole Φ4/No Pin	Punch/TT 85 ABS Slitting Punch/A/TiCN	RO Φ2
	Pole Φ4/No Pin	Punch/TT 85 ABS Slitting Punch/A/KPM	RO Φ3
	Pole Φ4/No Pin	Punch/TT 85 ABS Slitting Punch/A/Hard Alloy	RO Φ2
	Pole Φ4/No Pin	Punch/TT 85 ABS Slitting Punch/A/Hard Alloy	RO Φ2.5
	Pole Φ4/No Pin	Punch/TT 85 ABS Slitting Punch/A	RO Φ4
	Pole Φ6/No Pin	Punch/TT 85 ABS Slitting Punch/A/TiCN	RO Φ5
	Pole Φ6/No Pin	Punch/TT 85 ABS Slitting Punch/A/KPM	RO Φ6
	7# Punch/Thick Turret 80 Punch		
	No Pin	Punch/TT 80 Punch/A	RO Φ5
	No Pin	Punch/TT 80 Punch/A/TiCN	RO Φ5
	No Pin	Punch/TT 80 Punch/A/KPM	RO Φ5
	Pin	Punch/TT 80 Punch/A	RE 2*10
	Pin	Punch/TT 80 Punch/A/TiCN	OB Φ3*10
	Pin	Punch/TT 80 Punch/A/KPM	SQ 5*5
8# Punch/Thick Turret 80 Heavy Duty Punch			
	No Pin	Punch/TT 80 Heavy Duty Punch/A	RO Φ5
	No Pin	Punch/TT 80 Heavy Duty Punch/A/TiCN	RO Φ5
	No Pin	Punch/TT 80 Heavy Duty Punch/A/KPM	RO Φ5
	Pin	Punch/TT 80 Heavy Duty Punch/A	RE 2*10
	Pin	Punch/TT 80 Heavy Duty Punch/A/TiCN	OB Φ3*10
	Pin	Punch/TT 80 Heavy Duty Punch/A/KPM	SQ 5*5
9# Punch/Thick Turret 90 Punch			
	No Pin	Punch/TT 90 Punch/A	RO Φ5
	No Pin	Punch/TT 90 Punch/A/TiCN	RO Φ5
	No Pin	Punch/TT 90 Punch/A/KPM	RO Φ5
	Pin	Punch/TT 90 Punch/A	RE 2*10
	Pin	Punch/TT 90 Punch/A/TiCN	OB Φ3*10
	Pin	Punch/TT 90 Punch/A/Blanking	SQ 5*5-0.2

*** PA: Punch Ass'y *** TT: Thick Turret *** TiCN: Coating *** PHA: Punch Head Ass'y *** KPM: KETEC Powder Material

THICK TURRET
A STN

A STN (Size Range:ΦD:1.0~12.7mm)

THICK TURRET
A STN

90 ABS Punch	Slot	Description	Size (e.g.)
10# Punch/Thick Turret 90 ABS Punch			
	No Pin	Punch/TT 90 ABS Punch/A	RO Φ5
	No Pin	Punch/TT 90 ABS Punch/A/TiCN	RO Φ5
	No Pin	Punch/TT 90 ABS Punch/A/KPM	RO Φ5
	Pin	Punch/TT 90 ABS Punch/A	RE 2*10
	Pin	Punch/TT 90 ABS Punch/A/TiCN	OB Φ3*10
	Pin	Punch/TT 90 ABS Punch/A/KPM	SQ 5*5

11# Punch/Thick Turret KU Punch			
	Pin	Punch/TT KU Punch/A	RO Φ5
	Pin	Punch/TT KU Punch/A/TiCN	RO Φ5
	Pin	Punch/TT KU Punch/A/KPM	RO Φ5
	Pin	Punch/TT KU Punch/A	RE 2*10
	Pin	Punch/TT KU Punch/A/TiCN	OB Φ3*10
	Pin	Punch/TT KU Punch/A/KPM	SQ 5*5

Guide	Slot	Description	Size (e.g.)
-------	------	-------------	-------------

1# Guide/Thick Turret 85 Guide			
	1 Slot	Guide/TT 85 Guide/A	RO Φ5
	(0,90)	Guide/TT 85 Guide/A	RE 2*10
	(0,135)	Guide/TT 85 Guide/A	SQ 5*5
	3 Slots	Guide/TT 85 Guide/A/(0,45,90)	Ellipse /A*B*R
	4 Slots	Guide/TT 85 Guide/A/(0,90,180,270)	RO 1 Slot B2/ØD*A

2# Guide/Thick Turret 85 Open Guide			
	1 Slot	Guide/TT 85 Open Guide/A	
	(0,90)	Guide/TT 85 Open Guide/A	
	(0,135)	Guide/TT 85 Open Guide/A	

3# Guide/Thick Turret 85 ABS Guide			
	1 Slot	Guide/TT 85 ABS Guide/A	RO Φ5
	(0,90)	Guide/TT 85 ABS Guide/A	RE 2*10
	(0,135)	Guide/TT 85 ABS Guide/A	SQ 5*5
	3 Slots	Guide/TT 85 ABS Guide/A/(0,45,90)	Pentagon A8/A*B
	4 Slots	Guide/TT 85 ABS Guide/A/(0,90,180,270)	Non Standard Circle B22/A*B

4# Guide/Thick Turret 85 ABS Open Guide			
	1 Slot	Guide/TT 85 ABS Open Guide/A	
	(0,90)	Guide/TT 85 ABS Open Guide/A	
	(0,135)	Guide/TT 85 ABS Open Guide/A	

5# Guide/Thick Turret 85 Fully Guided Guide			
	1 Slot	Guide/TT 85 Fully Guided Guide/A	RO Φ5
	(0,90)	Guide/TT 85 Fully Guided Guide/A	RE 2*10
	(0,135)	Guide/TT 85 Fully Guided Guide/A	SQ 5*5
	3 Slots	Guide/TT 85 Fully Guided Guide/A/(0,45,90)	Class A A13/A*B
	4 Slots	Guide/TT 85 Fully Guided Guide/A/(0,90,180,270)	Class B B13/A*B

6# Guide/Thick Turret 85 ABS Fully Guided Guide			
	1 Slot	Guide/TT 85 ABS Fully Guided Guide/A	RO Φ5
	(0,90)	Guide/TT 85 ABS Fully Guided Guide/A	RE 2*10
	(0,135)	Guide/TT 85 ABS Fully Guided Guide/A	SQ 5*5
	3 Slots	Guide/TT 85 ABS Fully Guided Guide/A/(0,45,90)	4-Way Radius A16/A*B
	4 Slots	Guide/TT 85 ABS Fully Guided Guide/A/(0,90,180,270)	Class B B19/A*B

7# Guide/Thick Turret KU Guide			
	1 Slot	Guide/Thick Turret KUGuide/A	
	(0,90)	Guide/Thick Turret KUGuide/A	
	(0,135)	Guide/Thick Turret KUGuide/A	

8# Guide/Thick Turret 90 Guide			
	1 Slot	Guide/Thick Turret 90 Guide/A	
	(0,90)	Guide/Thick Turret 90 Guide/A	
	(0,135)	Guide/Thick Turret 90 Guide/A	
	3 Slots	Guide/Thick Turret 90 Guide/A/(0,45,90)	

9# Guide/Thick Turret 90 ABS Guide			
	1 Slot	Guide/Thick Turret 90 ABS Guide/A	
	(0,90)	Guide/Thick Turret 90 ABS Guide/A	
	(0,135)	Guide/Thick Turret 90 ABS Guide/A	
	3 Slots	Guide/Thick Turret 90 ABS Guide/A/(0,45,90)	
	4 Slots	Guide/Thick Turret 90 ABS Guide/A/(0,90,180,270)	

A STN (Size Range:ΦD:1.0~12.7mm)

THICK TURRET
A STN

A STN Die		Slot	Description	Size(e.g.)
1# Die/Thick Turret Die				
	No Slot		Die/Thick Turret Die/A	RO Φ4+0.2
	Slot		Die/Thick Turret Die/A	RE 5*10+0.25
	Slot		Die/Thick Turret Die/A/M2	SQ 3*3+0.3
	Slot		Die/Thick Turret Die/A/(45)	OB Φ2*8+0.15
2# Die/Thick Turret Die/slughugger				
	No Slot		Die/Thick Turret Die/A	RO Φ5+0.25/slughugger-1
	No Slot		Die/Thick Turret Die/A	RO Φ5+0.4/slughugger-1
	Slot		Die/Thick Turret Die/A	RE 5*10+0.2/slughugger
	Slot		Die/Thick Turret Die/A	SQ 3*3+0.3/slughugger
	Slot		Die/Thick Turret Die/A	OB Φ2*8+0.15/slughugger
3# Die/Thick Turret Vacuum Die				
	No Slot		Die/Thick Turret Vaccum Die/A	RO Φ10+0.4
	No Slot		Die/Thick Turret Vaccum Die/A	RO Φ5+0.2
	Slot		Die/Thick Turret Vaccum Die/A	RE 5*10+0.2
	Slot		Die/Thick Turret Vaccum Die/A/M2	SQ 3*3+0.3
	Slot		Die/Thick Turret Vaccum Die/A/M2	OB Φ2*8+0.15
4# Die/Thick Turret Heavy Duty Die				
	No Slot		Die/Thick Turret Heavy Duty Die/A	RO Φ10+0.6
	No Slot		Die/Thick Turret Heavy Duty Die/A	RO Φ5+0.4
	Slot		Die/Thick Turret Heavy Duty Die/A	RE 5*10+0.5
	Slot		Die/Thick Turret Heavy Duty Die/A	SQ 8*8+0.8
	Slot		Die/Thick Turret Heavy Duty Die/A	OB Φ6*10+0.8
5# Die/Thick Turret Heavy Duty Die/Slughugger				
	No Slot		Die/Thick Turret Heavy Duty Die/A	RO Φ10+0.6/slughugger-1
	No Slot		Die/Thick Turret Heavy Duty Die/A	RO Φ5+0.4/slughugger-1
	Slot		Die/Thick Turret Heavy Duty Die/A	RE 5*10+0.5/slughugger
	Slot		Die/Thick Turret Heavy Duty Die/A	SQ 8*8+0.8/slughugger
	Slot		Die/Thick Turret Heavy Duty Die/A	OB Φ6*10+0.8/slughugger
6# Die/Thick Turret Combination Die				
	No Slot		Die/TT Combination Die/A/KPM	RO Φ2+0.2
	No Slot		Die/TT Combination Die/A/Alloy	RO Φ2+0.2
	No Slot		Die/TT Combination Die/A/Alloy	RO Φ2.5+0.2
	Slot		Die/TT Combination Die/A/KPM	SQ 2*2+0.3
	Slot		Die/TT Combination Die/A/KPM	SQ 2*2+0.3
7# Die/Thick Turret Close To Clamp Die				
	No Slot		Die/Thick Turret CTC Die/A	Customized
	Slot		Die/Thick Turret CTC Die/A	Customized
8# Die/Thick Turret Die/Blanking				
	No Slot		Die/Thick Turret Die/A/Blanking	RO Φ6
	No Slot		Die/Thick Turret Die/A/Blanking	RO Φ10
	Slot		Die/Thick Turret Die/A/Blanking	RE 5*10
	Slot		Die/Thick Turret Die/A/Blanking	SQ 3*3
	Slot		Die/Thick Turret Die/A/Blanking	OB Φ2.8



*** M2: Material of SKH51

*** KPM: KETEC Powder Material

A STN (Size Range:ΦD:1.0~12.7mm)

THICK TURRET
A STN

A STN Die	Slot	Description	Size(e.g.)
9# Die/Thick Turret Special Die			
	NA	Die/TT Blank Die/A	
	NA	Die Assy/TT Roller Ball Die Assy/A	
	NA	Die Assy/TT Blush Die Assy/A	











A STN Stripper	Description	Size(e.g.)
1# Stripper/Thick Turret 90 Stripper		
	Stripper/Thick Turret 90 Stripper/A	OB Φ5*10
	Stripper/Thick Turret 90 Stripper/A	RO Φ6
	Stripper/Thick Turret 90 Stripper/A	RE 5*10
	Stripper/Thick Turret 90 Stripper/A/Blanking	SQ 8*8-0.2
2# Stripper/Thick Turret 90 ABS Stripper		
	Stripper/Thick Turret 90 ABS Stripper/A	OB Φ5*10
	Stripper/Thick Turret 90 ABS Stripper/A	RO Φ6
	Stripper/Thick Turret 90 ABS Stripper/A	RE 5*10
	Stripper/Thick Turret 90 ABS Stripper/A/Blanking	SQ 8*8-0.2
3# Stripper/Thick Turret KU Stripper		
	Stripper/Thick Turret KU Stripper/A	OB Φ5*10
	Stripper/Thick Turret KU Stripper/A	RO Φ6
	Stripper/Thick Turret KU Stripper/A	RE 5*10
	Stripper/Thick Turret KU Stripper/A/Blanking	SQ 8*8-0.2

Punch Head Ass'y	Punch Head Ass'y
1# Punch Head Ass'y/Thick Turret T85 Punch Head Ass'y	2# Punch Head Ass'y/Thick Turret T85 Light Duty Punch Head Ass'y
 PHA/TT T85 PHA/A	 PHA/TT T85 Light Duty PHA/A
3# Punch Head Ass'y/Thick Turret T90 Punch Head Ass'y	4# Punch Head Ass'y/Thick Turret T90 Heavy Duty Punch Head Ass'y
 PHA/TT T90 PHA/A	 PHA/TT T90 Heavy Duty PHA/A
5# Punch Head Ass'y/Thick Turret KU Punch Head Ass'y	6# Punch Head Ass'y/Thick Turret E85 Punch Head Ass'y
 PHA/TT KU Punch Head Ass'y/A	 PHA/TT E85 PHA/A
7# Punch Head Ass'y/Thick Turret E85 Light Duty Punch Head Ass'y	8# Punch Head Ass'y/Thick Turret E80 Punch Head Ass'y
 PHA/TT E85 Light Duty PHA/A	 PHA/TT E80 PHA/A
9# Punch Head Ass'y/Thick Turret E80 Heavy Duty Punch Head Ass'y	10# Punch Head Ass'y/Thick Turret E80 Heavy Duty SH Punch Head Ass'y
 PHA/TT E80 Heavy Duty PHA/A	 PHA/TT E80 Heavy Duty SH PHA/A

B STN-Thick Turret Punch Ass'y Index





B STN

T Series

<p>T85</p> <p>P19</p>  <p>1 85 Punch 2 85 Guide 3 T85 Punch Head Assy</p>	<p>T85 Light Duty</p> <p>P19</p>  <p>1 85 Punch 2 85 Guide 3 T85 Light Duty Punch Head Assy</p>	<p>T85 Fully Guided</p> <p>P20</p>  <p>1 85 Fully Guided Punch 2 85 Fully Guided Guide 3 T85 Punch Head Assy</p>	<p>T85 Open Guide</p> <p>P21</p>  <p>1 85 Punch 2 85 Open Guide 3 T85 Punch Head Assy 4 90 Stripper</p>	<p>T85 ABS</p> <p>P21</p>  <p>1 85 ABS Punch 2 85 ABS Guide 3 T85 Punch Head Assy</p>	<p>T85 ABS Fully Guided</p> <p>P22</p>  <p>1 85 ABS Fully Guided Punch 2 85 ABS Fully Guided Guide 3 T85 Punch Head Assy</p>
<p>T85 Open Guide ABS</p> <p>P30</p>  <p>1 85 ABS Punch 2 85 ABS Open Guide 3 T85 Punch Head Assy 4 90 ABS Stripper</p>	<p>T90</p> <p>P30</p>  <p>1 90 Punch 2 90 Guide 3 T90 Punch Head Assy 4 90 Stripper</p>	<p>T90 ABS</p> <p>P31</p>  <p>1 90 ABS Punch 2 90 ABS Guide 3 T90 Punch Head Assy 4 90 ABS Stripper</p>	<p>T90 Heavy Duty</p> <p>P32</p>  <p>1 90 Heavy Duty Punch 2 90 Guide 3 T90 Heavy Duty Punch Head Assy 4 90 Stripper</p>		

THICK TURRET
B STN

E Series

<p>E85</p> <p>P32</p>  <p>1 85 Punch 2 85 Guide 3 E85 Punch Head Assy</p>	<p>E85 Light Duty</p> <p>P33</p>  <p>1 85 Punch 2 85 Guide 3 E85 Light Duty Punch Head Assy</p>	<p>E80</p> <p>P27</p>  <p>1 80 Punch 2 80 Guide 3 E80 Punch Head Assy 4 80 Stripper</p>	<p>E80 Heavy Duty</p> <p>P27</p>  <p>1 80 Heavy Duty Punch 2 80 Guide 3 E80 Heavy Duty Punch Head Assy 4 80 Stripper</p>	<p>E80 Heavy Duty SH</p> <p>P28</p>  <p>1 80 Heavy Duty Punch 2 80 Guide 3 E80 Heavy Duty SH Punch Head Assy 4 80 Stripper</p>
---	---	---	--	--

K Series





<p>KU</p> <p>P29</p>  <p>1 KU Punch 2 KU Guide 3 KU PHA 4 KU Stripper</p>

B STN (Size Range:ΦD:12.71~31.7mm)



T85	Slot	Description	Size (e.g.)
1# Punch Ass'y/Thick Turret T85 Punch Ass'y			
	1 Slot	PA/TT T85 PA/B	RO Φ15
	1 Slot	PA/TT T85 PA/B/TiCN	RO Φ15
	1 Slot	PA/TT T85 PA/B/KPM	RO Φ15
	(0,90)	PA/TT T85 PA/B	RE 5*30
	(0,90)	PA/TT T85 PA/B/TiCN	RE 5*30
	(0,90)	PA/TT T85 PA/B/KPM	RE 5*30
	(0,90)	PA/TT T85 PA/B/(45)	RE 3*25
	(0,90)	PA/TT T85 PA/B/(90)	RE 4*30
	(0,90)	PA/TT T85 PA/B/(0,90)	RE 15*15
	(0,90)	PA/TT T85 PA/B/(135)	RE 3*25
	(0,90)	PA/TT T85 PA/B/TiCN/(0,90)	SQ 15*15
	(0,90)	PA/TT T85 PA/B/KPM/(0,90)	SQ 10*10
	(0,135)	PA/TT T85 PA/B	SQ 15*15
	(0,135)	PA/TT T85 PA/B/TiCN	SQ 15*15
	(0,135)	PA/TT T85 PA/B/KPM	SQ 15*15
	(0,45,90)	PA/TT T85 PA/B/(0,45,90)	OB Φ8*16
	(0,90,180,270)	PA/TT T85 PA/B/(0,90,180,270)	Triangle A2/A*B
	(0,90,180,270)	PA/TT T85 PA/B/TiCN/(0,90,180,270)	One Way Radius B7/A*B*R
	(0,90,180,270)	PA/TT T85 PA/B/KPM/(0,90,180,270)	Key Hole C3/Ød*A
	(0,90)	PA/TT T85 PA/B/Blanking	RE 5*30-0.2
1.1 Punch/Thick Turret 85 Punch			
	No Pin	Punch/TT 85 Punch/B	RO Φ15
	Pin	Punch/TT 85 Punch/B	RE 5*30
	Pin	Punch/TT 85 Punch/B/Blanking	SQ 15*15-0.2
	Pin	Punch/TT 85 Punch/B/TiCN	SQ 15*15
	Pin	Punch/TT 85 Punch/B/KPM	RE 5*30
	Pin	Punch/TT 85 Punch/B/(45)	RE 3*25
1.2 Guide/Thick Turret 85 Guide			
	1 Slot	Guide/TT 85 Guide/B	RO Φ15
	(0,90)	Guide/TT 85 Guide/B	RE 5*25
	(0,90)	Guide/TT 85 Guide/B/(45)	RE 3*25
	(0,90)	Guide/TT 85 Guide/B/(90)	RE 4*30
	(0,90)	Guide/TT 85 Guide/B/(0,90)	SQ 15*15
	(0,135)	Guide/TT 85 Guide/B/Blanking	SQ 15*15-0.2
	(0,45,90)	Guide/TT 85 Guide/B/(0,45,90)	OB Φ8*16
	(0,90,180,270)	Guide/TT 85 Guide/B/(0,90,180,270)	Class C FT/A*B
1.3 Punch Head Ass'y/Thick Turret T85 Punch Head Ass'y			
		PHA/TT T85 PHA/B	
T85 Light Duty	Slot	Description	Size (e.g.)
2# Punch Ass'y/Thick Turret T85 Light Duty Punch Ass'y			
	1 Slot	PA/TT T85 Light Duty PA/B	RO Φ15
	1 Slot	PA/TT T85 Light Duty PA/B/TiCN	RO Φ15
	1 Slot	PA/TT T85 Light Duty PA/B/KPM	RO Φ15
	(0,90)	PA/TT T85 Light Duty PA/B	RE 5*30
	(0,90)	PA/TT T85 Light Duty PA/B/TiCN	RE 5*30
	(0,90)	PA/TT T85 Light Duty PA/B/KPM	RE 5*30
	(0,90)	PA/TT T85 Light Duty PA/B/(45)	RE 3*25
	(0,90)	PA/TT T85 Light Duty PA/B/(90)	RE 4*30
	(0,90)	PA/TT T85 Light Duty PA/B/(0,90)	SQ 15*15
	(0,90)	PA/TT T85 Light Duty PA/B/(135)	RE 3*25
	(0,90)	PA/TT T85 Light Duty PA/B/TiCN/(0,90)	SQ 15*15
	(0,90)	PA/TT T85 Light Duty PA/B/KPM/(0,90)	SQ 10*10
	(0,135)	PA/TT T85 Light Duty PA/B	SQ 15*15
	(0,135)	PA/TT T85 Light Duty PA/B/TiCN	SQ 15*15
	(0,135)	PA/TT T85 Light Duty PA/B/KPM	SQ 15*15
	(0,45,90)	PA/TT T85 Light Duty PA/B/(0,45,90)	OB Φ8*16
	(0,90,180,270)	PA/TT T85 Light Duty PA/B/(0,90,180,270)	HX S=A9/A*B
	(0,90,180,270)	PA/TT T85 Light Duty PA/B/TiCN/(0,90,180,270)	One Way Radius B8/A*B*R
	(0,90,180,270)	PA/TT T85 Light Duty PA/B/KPM/(0,90,180,270)	Class C FT/A*B

B STN (Size Range:ΦD:12.71~31.7mm)

THICK TURRET
B STN

85 Punch	Slot/Pin	Description	Size(e.g.)
2.1 Punch/Thick Turret 85 Punch			
	No Pin	Punch/TT 85 Punch/B	RO Φ15
	Pin	Punch/TT 85 Punch/B	RE 5*30
	Pin	Punch/TT 85 Punch/B	SQ 15*15
	Pin	Punch/TT 85 Punch/B/TiCN	SQ 15*15
	Pin	Punch/TT 85 Punch/B/KPM	RE 5*30
	Pin	Punch/TT 85 Punch/B/(45)	RE 3*25
2.2 Guide/Thick Turret 85 Guide			
	1 Slot	Guide/TT 85 Guide/B	RO Φ15
	(0,90)	Guide/TT 85 Guide/B	RE 5*25
	(0,90)	Guide/TT 85 Guide/B/(45)	RE 3*25
	(0,90)	Guide/TT 85 Guide/B/(90)	RE 4*30
	(0,90)	Guide/TT 85 Guide/B/(0,90)	SQ 15*15
	(0,135)	Guide/TT 85 Guide/B	SQ 15*15
	(0,45,90)	Guide/TT 85 Guide/B/(0,45,90)	OB Φ8*16
	(0,90,180,270)	Guide/TT 85 Guide/B/(0,90,180,270)	Wire Hole C10/A*B
2.3 Punch Head Ass'y/Thick Turret T85 Light Duty Punch Head Ass'y			
		PHA/TT T85 Light Duty PHA/B	

T85 Fully Guided	Slot/Pin	Description	Size(e.g.)
3# Punch Ass'y/Thick Turret T85 Fully Guided Punch Ass'y			
	(0,90)	PA/TT T85 Fully Guided PA/B	RO Φ15
	(0,90)	PA/TT T85 Fully Guided PA/B/TiCN	RO Φ15
	(0,90)	PA/TT T85 Fully Guided PA/B/KPM	RO Φ15
	(0,90)	PA/TT T85 Fully Guided PA/B	RE 5*30
	(0,90)	PA/TT T85 Fully Guided PA/B/TiCN	RE 5*30
	(0,90)	PA/TT T85 Fully Guided PA/B/KPM	RE 5*30
	(0,90)	PA/TT T85 Fully Guided PA/B/(45)	RE 3*25
	(0,90)	PA/TT T85 Fully Guided PA/B/(90)	RE 4*30
	(0,90)	PA/TT T85 Fully Guided PA/B/(0,90)	SQ 15*15
	(0,90)	PA/TT T85 Fully Guided PA/B/(135)	RE 3*25
	(0,90)	PA/TT T85 Fully Guided PA/B/TiCN/(0,90)	SQ 15*15
	(0,90)	PA/TT T85 Fully Guided PA/B/KPM/(0,90)	SQ 10*10

3.1 Punch/Thick Turret 85 Fully Guided Punch			
	No Pin	Punch/TT 85 Fully Guided Punch/B	
	Pin	Punch/TT 85 Fully Guided Punch/B	RE 5*30
	Pin	Punch/TT 85 Fully Guided Punch/B	SQ 15*15
	Pin	Punch/TT 85 Fully Guided Punch/B/TiCN	SQ 15*15
	Pin	Punch/TT 85 Fully Guided Punch/B/KPM	RE 5*30
	Pin	Punch/TT 85 Fully Guided Punch/B/(45)	RE 3*25







3.2 Guide/Thick Turret 85 Fully Guided Guide			
	(0,90)	Guide/TT 85 Fully Guided Guide/B	RO Φ15
	(0,90)	Guide/TT 85 Fully Guided Guide/B	RE 5*25
	(0,90)	Guide/TT 85 Fully Guided Guide/B/(45)	RE 3*25
	(0,90)	Guide/TT 85 Fully Guided Guide/B/(90)	RE 4*30
	(0,90)	Guide/TT 85 Fully Guided Guide/B/(0,90)	SQ 15*15

*** TT: Thick Turret
*** PA: Punch Ass'y

3.3 Punch Head Ass'y/Thick Turret T85 Punch Head Ass'y			
		PHA/TT T85 PHA/B	*** PHA: Punch Head Ass'y
			*** KPM: KETEC Powder Material
			*** TiCN: Coating

B STN (Size Range:ΦD:12.71~31.7mm)

THICK TURRET
B STN

T85 Open Guide	Slot	Description	Size (e.g.)
4# Punch Ass'y/Thick Turret T85 Open Guide Punch Ass'y			
	1 Slot	PA/Thick Turret T85 Open Guide PA/B	RO Φ15
	1 Slot	PA/Thick Turret T85 Open Guide PA/B/TiCN	RO Φ15
	1 Slot	PA/Thick Turret T85 Open Guide PA/B/KPM	RO Φ15
	(0,90)	PA/Thick Turret T85 Open Guide PA/B	RE 5*30
	(0,90)	PA/Thick Turret T85 Open Guide PA/B/TiCN	RE 5*30
	(0,90)	PA/Thick Turret T85 Open Guide PA/B/KPM	RE 5*30
	(0,90)	PA/Thick Turret T85 Open Guide PA/B/(45)	RE 3*25
	(0,90)	PA/Thick Turret T85 Open Guide PA/B/(90)	RE 4*30
	(0,90)	PA/Thick Turret T85 Open Guide PA/B/(0,90)	SQ 15*15
	(0,90)	PA/Thick Turret T85 Open Guide PA/B/(135)	RE 3*25
	(0,90)	PA/Thick Turret T85 Open Guide PA/B/TiCN/(0,90)	SQ 15*15
	(0,90)	PA/Thick Turret T85 Open Guide PA/B/KPM/(0,90)	SQ 10*10
	(0,135)	PA/Thick Turret T85 Open Guide PA/B	SQ 15*15
	(0,135)	PA/Thick Turret T85 Open Guide PA/B/TiCN	SQ 15*15
	(0,135)	PA/Thick Turret T85 Open Guide PA/B/KPM	SQ 15*15
	4.1 Punch/Thick Turret 85 Punch		
	No Pin	Punch/Thick Turret 85Punch/B	RO Φ15
	Pin	Punch/Thick Turret 85 Punch/B	RE 5*30
	Pin	Punch/Thick Turret 85 Punch/B	SQ 15*15
	Pin	Punch/Thick Turret 85 Punch/B/TiCN	SQ 15*15
	Pin	Punch/Thick Turret 85 Punch/B/KPM	RE 5*30
	Pin	Punch/Thick Turret 85 Punch/B/(45)	RE 3*25
4.2 Guide/Thick Turret 85 Open Guide			
	1 Slot	Guide/Thick Turret 85 Open Guide/B	
	(0,90)	Guide/Thick Turret 85 Open Guide/B	
	(0,135)	Guide/Thick Turret 85 Open Guide/B	
4.3 Punch Head Ass'y/Thick Turret T85 Punch Head Ass'y		4.4 Stripper/Thick Turret 90 Stripper	
	PHA/TT T85 PHA/B		Stripper/TT 90 Stripper/B

T85 ABS	Slot	Description	Size (e.g.)
5# Punch Ass'y/Thick Turret T85 ABS Punch Ass'y			
	1 Slot	PA/Thick Turret T85 ABS PA/B	RO Φ15
	1 Slot	PA/Thick Turret T85 ABS PA/B/TiCN	RO Φ15
	1 Slot	PA/Thick Turret T85 ABS PA/B/KPM	RO Φ15
	(0,90)	PA/Thick Turret T85 ABS PA/B	RE 5*30
	(0,90)	PA/Thick Turret T85 ABS PA/B/TiCN	RE 5*30
	(0,90)	PA/Thick Turret T85 ABS PA/B/KPM	RE 5*30
	(0,90)	PA/Thick Turret T85 ABS PA/B/(45)	RE 3*25
	(0,90)	PA/Thick Turret T85 ABS PA/B/(90)	RE 4*30
	(0,90)	PA/Thick Turret T85 ABS PA/B/(0,90)	SQ 15*15
	(0,90)	PA/Thick Turret T85 ABS PA/B/(135)	RE 3*25
	(0,90)	PA/Thick Turret T85 ABS PA/B/TiCN/(0,90)	SQ 15*15
	(0,90)	PA/Thick Turret T85 ABS PA/B/KPM/(0,90)	SQ 10*10
	(0,135)	PA/Thick Turret T85 ABS PA/B	SQ 15*15
	(0,135)	PA/Thick Turret T85 ABS PA/B/TiCN	SQ 15*15
	(0,135)	PA/Thick Turret T85 ABS PA/B/KPM	SQ 15*15
	(0,90,180,270)	PA/Thick Turret T85 ABS PA/B/(0,90,180,270)	Class A OB A1/A*B
	(0,90,180,270)	PA/Thick Turret T85 ABS PA/B/TiCN/(0,90,180,270)	Class B 16/A*B
	(0,90,180,270)	PA/Thick Turret T85 ABS PA/B/KPM/(0,90,180,270)	Class C FT/A*B
(0,90)	PA/Thick Turret T85 ABS PA/B/Blanking	RE 5*30-0.3	







B STN (Size Range:ΦD:12.71~31.7mm)

THICK TURRET
B STN

Fully Guided	Slot	Description	Size(e.g.)
5.1 Punch/Thick Turret 85 ABS Punch			
	No Pin	Punch/TT 85 ABS Punch/B	RO Φ15
	Pin	Punch/TT 85 ABS Punch/B	RE 5*30
	Pin	Punch/TT 85 ABS Punch/B/Blanking	SQ 15*15-0.2
	Pin	Punch/TT 85 ABS Punch/B/TiCN	SQ 15*15
	Pin	Punch/TT 85 ABS Punch/B/KPM	RE 5*30
	Pin	Punch/TT 85 ABS Punch/B/(45)	RE 3*25
5.2 Guide/Thick Turret 85 ABS Guide			
	No Pin	Guide/Thick Turret 85 ABS Guide/B	RO Φ15
	(0,90)	Guide/Thick Turret 85 ABS Guide/B	RE 5*25
	(0,90)	Guide/Thick Turret 85 ABS Guide/B/(45)	RE 3*25
	(0,90)	Guide/Thick Turret 85 ABS Guide/B/(90)	RE 4*30
	(0,90)	Guide/Thick Turret 85 ABS Guide/B/(0,90)	SQ 15*15
	(0,135)	Guide/Thick Turret 85 ABS Guide/B/Blanking	SQ 15*15-0.2
	(0,90,180,270)	Guide/Thick Turret 85 ABS Guide/B/(0,90,180,270)	Class C FT/A*B
5.3 Punch Head Ass'y/Thick Turret T85 Punch Head Ass'y			
		PHA/TT T85 PHA/B	
T85 ABS Fully Guided			
T85 ABS Fully Guided	Slot	Description	Size(e.g.)
6# Punch Ass'y/Thick Turret T85 ABS Fully Guided Punch Ass'y			
	(0,90)	PA/Thick Turret T85 ABS Fully Guided PA/B	RO Φ15
	(0,90)	PA/Thick Turret T85 ABS Fully Guided PA/B/TiCN	RO Φ15
	(0,90)	PA/Thick Turret T85 ABS Fully Guided PA/B/KPM	RO Φ15
	(0,90)	PA/Thick Turret T85 ABS Fully Guided PA/B	RE 5*30
	(0,90)	PA/Thick Turret T85 ABS Fully Guided PA/B/TiCN	RE 5*30
	(0,90)	PA/Thick Turret T85 ABS Fully Guided PA/B/KPM	RE 5*30
	(0,90)	PA/Thick Turret T85 ABS Fully Guided PA/B/(45)	RE 3*25
	(0,90)	PA/Thick Turret T85 ABS Fully Guided PA/B/(90)	RE 4*30
	(0,90)	PA/Thick Turret T85 ABS Fully Guided PA/B/(0,90)	SQ 15*15
	(0,90)	PA/Thick Turret T85 ABS Fully Guided PA/B/(135)	RE 3*25
	(0,90)	PA/Thick Turret T85 ABS Fully Guided PA/B/TiCN/(0,90)	SQ 15*15
	(0,90)	PA/Thick Turret T85 ABS Fully Guided PA/B/KPM/(0,90)	SQ 10*10
6.1 Punch/Thick Turret 85 ABS Fully Guided Punch			
	No Pin	Punch/Thick Turret 85 ABS Fully Guided Punch/B	
	Pin	Punch/Thick Turret 85 ABS Fully Guided Punch/B	RE 5*30
	Pin	Punch/Thick Turret 85 ABS Fully Guided Punch/B	SQ 15*15
	Pin	Punch/Thick Turret 85 ABS Fully Guided Punch/B/TiCN	SQ 15*15
	Pin	Punch/Thick Turret 85 ABS Fully Guided Punch/B/KPM	RE 5*30
	Pin	Punch/Thick Turret 85 ABS Fully Guided Punch/B/(45)	RE 3*25
6.2 Guide/Thick Turret 85 ABS Fully Guided Guide			
	(0,90)	Guide/Thick Turret 85 ABS Fully Guided Guide/B	RO Φ15
	(0,90)	Guide/Thick Turret 85 ABS Fully Guided Guide/B	RE 5*25
	(0,90)	Guide/Thick Turret 85 ABS Fully Guided Guide/B/(45)	RE 3*25
	(0,90)	Guide/Thick Turret 85 ABS Fully Guided Guide/B/(90)	RE 4*30
	(0,90)	Guide/Thick Turret 85 ABS Fully Guided Guide/B/(0,90)	SQ 15*15
			*** ABS: ABS
			*** TT: Thick Turret
			*** PA: Punch Ass'y
6.3 Punch Head Ass'y/Thick Turret T85 Punch Head Ass'y			
		Punch Head Ass'y/Thick Turret T85 Punch Head Ass'y/B	*** PHA: Punch Head Ass'y
			*** KPM: KETEC Powder Material
			*** TiCN: Coating

B STN (Size Range:ΦD:12.71~31.7mm)

THICK TURRET
B STN

T85 Open Guide ABS	Slot	Description	Size (e.g.)
7# Punch Ass'y/Thick Turret T85 Open Guide ABS Punch Ass'y			
	1 Slot	PA/Thick Turret T85 Open Guide ABS PA/B	RO Φ15
	1 Slot	PA/Thick Turret T85 Open Guide ABS PA/B/TiCN	RO Φ15
	1 Slot	PA/Thick Turret T85 Open Guide ABS PA/B/KPM	RO Φ15
	(0,90)	PA/Thick Turret T85 Open Guide ABS PA/B	RE 5*30
	(0,90)	PA/Thick Turret T85 Open Guide ABS PA/B/TiCN	RE 5*30
	(0,90)	PA/Thick Turret T85 Open Guide ABS PA/B/KPM	RE 5*30
	(0,90)	PA/Thick Turret T85 Open Guide ABS PA/B/(45)	RE 3*25
	(0,90)	PA/Thick Turret T85 Open Guide ABS PA/B/(90)	RE 4*30
	(0,90)	PA/Thick Turret T85 Open Guide ABS PA/B/(0,90)	SQ 15*15
	(0,90)	PA/Thick Turret T85 Open Guide ABS PA/B/(135)	RE 3*25
	(0,90)	PA/Thick Turret T85 Open Guide ABS PA/B/(0,90)	SQ 15*15
	(0,90)	PA/Thick Turret T85 Open Guide ABS PA/B/KPM/(0,90)	SQ 10*10
	(0,135)	PA/Thick Turret T85 Open Guide ABS PA/B	SQ 15*15
	(0,135)	PA/Thick Turret T85 Open Guide ABS PA/B/TiCN	SQ 15*15
	(0,135)	PA/Thick Turret T85 Open Guide ABS PA/B/KPM	SQ 15*15
	7.1 Punch/Thick Turret 85 ABS Punch		
	No Pin	Punch/Thick Turret 85 ABS Punch/B	RO Φ15
	Pin	Punch/Thick Turret 85 ABS Punch/B	RE 5*30
	Pin	Punch/Thick Turret 85 ABS Punch/B	SQ 15*15
	Pin	Punch/Thick Turret 85 ABS Punch/B/TiCN	SQ 15*15
	Pin	Punch/Thick Turret 85 ABS Punch/B/KPM	RE 5*30
	Pin	Punch/Thick Turret 85 ABS Punch/B/(45)	RE 3*25
7.2 Guide/Thick Turret 85 ABS Open Guide Guide			
	1 Slot	Guide/Thick Turret 85 ABS Open Guide Guide/B	
	(0,90)	Guide/Thick Turret 85 ABS Open Guide Guide/B	
	(0,135)	Guide/Thick Turret 85 ABS Open Guide Guide/B	
7.3 Punch Head Ass'y/Thick Turret T85 Punch Head Ass'y		7.4 Stripper/Thick Turret 90 ABS Stripper	
		Punch Head Ass'y/Thick Turret T85 Punch Head Ass'y	
			Stripper/TT 90 ABS Stripper/B

T90	Slot	Description	Size (e.g.)
8# Punch Ass'y/Thick Turret T90 Punch Ass'y			
	1 Slot	PA/Thick Turret T90 PA/B	RO Φ15
	1 Slot	PA/Thick Turret T90 PA/B/TiCN	RO Φ15
	1 Slot	PA/Thick Turret T90 PA/B/KPM	RO Φ15
	(0,90)	PA/Thick Turret T90 PA/B/Blanking	RE 5*30-0.2
	(0,90)	PA/Thick Turret T90 PA/B/TiCN	RE 5*30
	(0,90)	PA/Thick Turret T90 PA/B/KPM	RE 5*30
	(0,90)	PA/Thick Turret T90 PA/B/(45)	RE 3*25
	(0,90)	PA/Thick Turret T90 PA/B/(90)	RE 4*30
	(0,90)	PA/Thick Turret T90 PA/B/(0,90)	SQ 15*15
	(0,90)	PA/Thick Turret T90 PA/B/(135)	RE 3*25
	(0,90)	PA/Thick Turret T90 PA/B/TiCN/(0,90)	SQ 15*15
	(0,90)	PA/Thick Turret T90 PA/B/KPM/(0,90)	SQ 10*10
	(0,135)	PA/Thick Turret T90 PA/B	SQ 15*15
	(0,135)	PA/Thick Turret T90 PA/B/TiCN	SQ 15*15
	(0,135)	PA/Thick Turret T90 PA/B/KPM	SQ 15*15
	(0,45,90)	PA/Thick Turret T90 PA/B/(0,45,90)	OB Φ8*16
	(0,90,180,270)	PA/Thick Turret T90 PA/B/(0,90,180,270)	Class A A6/A*B
	(0,90,180,270)	PA/Thick Turret T90 PA/B/TiCN/(0,90,180,270)	Class B B10/A*B
(0,90,180,270)	PA/Thick Turret T90 PA/B/KPM/(0,90,180,270)	Class C C1/Ød*A	

B STN (Size Range:ΦD:12.71~31.7mm)

THICK TURRET
B STN





T90	Slot	Description	Size(e.g.)
8.1 Punch/Thick Turret 90 Punch			
	No Pin	Punch/Thick Turret 90 Punch/B	RO Φ15
	Pin	Punch/Thick Turret 90 Punch/B	RE 5*30
	Pin	Punch/Thick Turret 90 Punch/B/Blanking	SQ 15*15-0.2
	Pin	Punch/Thick Turret 90 Punch/B/TiCN	SQ 15*15
	Pin	Punch/Thick Turret 90 Punch/B/KPM	RE 5*30
	Pin	Punch/Thick Turret 90 Punch/B/(45)	RE 3*25
8.2 Guide/Thick Turret 90 Guide			
	1 Slot	Guide/Thick Turret 90 Guide/B	
	(0,90)	Guide/Thick Turret 90 Guide/B	
	(0,135)	Guide/Thick Turret 90 Guide/B	
	(0,45,90)	Guide/Thick Turret 90 Guide/B/(0,45,90)	
	(0,90,180,270)	Guide/Thick Turret 90 Guide/B/(0,90,180,270)	
8.3 Punch Head Ass'y/Thick Turret T90 Punch Head Ass'y			8.4 Stripper/Thick Turret 90 Stripper
		PHA/TT T90 PHA/B	 Stripper/TT 90 Stripper/B Stripper/TT 90 Stripper/B/Blanking
T90 ABS	Slot	Description	Size(e.g.)
9# Punch Ass'y/Thick Turret T90 ABS Punch Ass'y			
	1 Slot	PA/Thick Turret T90 ABS PA/B	RO Φ15
	1 Slot	PA/Thick Turret T90 ABS PA/B/TiCN	RO Φ15
	1 Slot	PA/Thick Turret T90 ABS PA/B/KPM	RO Φ15
	(0,90)	PA/Thick Turret T90 ABS PA/B	RE 5*30
	(0,90)	PA/Thick Turret T90 ABS PA/B/TiCN	RE 5*30
	(0,90)	PA/Thick Turret T90 ABS PA/B/KPM	RE 5*30
	(0,90)	PA/Thick Turret T90 ABS PA/B/(45)	RE 3*25
	(0,90)	PA/Thick Turret T90 ABS PA/B/(90)	RE 4*30
	(0,90)	PA/Thick Turret T90 ABS PA/B/(0,90)	SQ 15*15
	(0,90)	PA/Thick Turret T90 ABS PA/B/(135)	RE 3*25
	(0,90)	PA/Thick Turret T90 ABS PA/B/TiCN/(0,90)	SQ 15*15
	(0,90)	PA/Thick Turret T90 ABS PA/B/KPM/(0,90)	SQ 10*10
	(0,135)	PA/Thick Turret T90 ABS PA/B	SQ 15*15
	(0,135)	PA/Thick Turret T90 ABS PA/B/TiCN	SQ 15*15
	(0,135)	PA/Thick Turret T90 ABS PA/B/KPM	SQ 15*15
	(0,45,90)	PA/Thick Turret T90 ABS PA/B/(0,45,90)	OB Φ8*16
	(0,90,180,270)	PA/Thick Turret T90 ABS PA/B/(0,90,180,270)	Class A A3/A*B
	(0,90,180,270)	PA/Thick Turret T90 ABS PA/B/TiCN/(0,90,180,270)	Class B B3/ØD*A
(0,90,180,270)	PA/Thick Turret T90 ABS PA/B/KPM/(0,90,180,270)	Class C FT/A*B	
9.1 Punch/Thick Turret 90 ABS Punch			
	No Pin	Punch/Thick Turret 90 ABS Punch/B	RO Φ15
	Pin	Punch/Thick Turret 90 ABS Punch/B	RE 5*30
	Pin	Punch/Thick Turret 90 ABS Punch/B	SQ 15*15
	Pin	Punch/Thick Turret 90 ABS Punch/B/TiCN	SQ 15*15
	Pin	Punch/Thick Turret 90 ABS Punch/B/KPM	RE 5*30
	Pin	Punch/Thick Turret 90 ABS Punch/B/(45)	RE 3*25
9.2 Guide/Thick Turret 90 ABS Guide			
	1 Slot	Guide/Thick Turret 90 ABS Guide/B	*** ABS: ABS
	(0,90)	Guide/Thick Turret 90 ABS Guide/B	*** TT: Thick Turret
	(0,135)	Guide/Thick Turret 90 ABS Guide/B	*** PA: Punch Ass'y
	(0,45,90)	Guide/Thick Turret 90 ABS Guide/B/(0,45,90)	
	(0,90,180,270)	Guide/Thick Turret 90 ABS Guide/B/(0,90,180,270)	*** PHA: Punch Head Ass'y *** KPM: KETEC Powder Material *** TiCN: Coating
9.3 Punch Head Ass'y/Thick Turret T90 Punch Head Ass'y			9.4 Stripper/Thick Turret ABS 90 Stripper
		PHA/Thick Turret T90 PHA/B	 Stripper/TT 90 ABS Stripper/B

B STN (Size Range:ΦD:12.71~31.7mm)

THICK TURRET
B STN



T90 Heavy Duty	Slot	Description	Size (e.g.)
10# Punch Ass'y/Thick Turret T90 Heavy Duty Punch Ass'y			
	1 Slot	PA/TT T90 Heavy Duty PA/B	RO Φ15
	1 Slot	PA/TT T90 Heavy Duty PA/B/TiCN	RO Φ15
	1 Slot	PA/TT T90 Heavy Duty PA/B/KPM	RO Φ15
	(0,90)	PA/TT T90 Heavy Duty PA/B	RE 5*30
	(0,90)	PA/TT T90 Heavy Duty PA/B/TiCN	RE 5*30
	(0,90)	PA/TT T90 Heavy Duty PA/B/KPM	RE 5*30
	(0,90)	PA/TT T90 Heavy Duty PA/B/(45)	RE 3*25
	(0,90)	PA/TT T90 Heavy Duty PA/B/(90)	RE 4*30
	(0,90)	PA/TT T90 Heavy Duty PA/B/(0,90)	SQ 15*15
	(0,90)	PA/TT T90 Heavy Duty PA/B/(135)	RE 3*25
	(0,90)	PA/TT T90 Heavy Duty PA/B/TiCN/(0,90)	SQ 15*15
	(0,90)	PA/TT T90 Heavy Duty PA/B/KPM/(0,90)	SQ 10*10
	(0,135)	PA/TT T90 Heavy Duty PA/B	SQ 15*15
	(0,135)	PA/TT T90 Heavy Duty PA/B/TiCN	SQ 15*15
	(0,135)	PA/TT T90 Heavy Duty PA/B/KPM	SQ 15*15
	(0,45,90)	PA/TT T90 Heavy Duty PA/B/(0,45,90)	OB Φ8*16
	(0,90,180,270)	PA/TT T90 Heavy Duty PA/B/(0,90,180,270)	Class A/A*60°
	(0,90,180,270)	PA/TT T90 Heavy Duty PA/B/TiCN/(0,90,180,270)	Class B/B5/ØD*A
(0,90,180,270)	PA/TT T90 Heavy Duty PA/B/KPM/(0,90,180,270)	Class C/FT/A*B	
10.1 Punch/Thick Turret 90 Heavy Duty Punch			
	No Pin	Punch/Thick Turret 90 Heavy Duty Punch/B	RO Φ15
	Pin	Punch/Thick Turret 90 Heavy Duty Punch/B	RE 5*30
	Pin	Punch/Thick Turret 90 Heavy Duty Punch/B	SQ 15*15
	Pin	Punch/Thick Turret 90 Heavy Duty Punch/B/TiCN	SQ 15*15
	Pin	Punch/Thick Turret 90 Heavy Duty Punch/B/KPM	RE 5*30
	Pin	Punch/Thick Turret 90 Heavy Duty Punch/B/(45)	RE 3*25
10.2 Guide/Thick Turret 90 Guide			
	1 Slot	Guide/Thick Turret 90 Guide/B	
	(0,90)	Guide/Thick Turret 90 Guide/B	
	(0,135)	Guide/Thick Turret 90 Guide/B	
	(0,45,90)	Guide/Thick Turret 90 Guide/B/(0,45,90)	
	(0,90,180,270)	Guide/Thick Turret 90 Guide/B/(0,90,180,270)	
10.3 Punch Head Ass'y/Thick Turret T90 Heavy Duty Punch Head Ass'y		PHA/Thick Turret T90 HD PHA/B	
10.4 Stripper/Thick Turret 90 Stripper		Stripper/TT 90 Stripper/B	

E85 B STN	Slot	Description	Size (e.g.)
11# Punch Ass'y/Thick Turret E85 Punch Ass'y			
	1 Slot	PA/Thick Turret E85 PA/B	RO Φ15
	1 Slot	PA/Thick Turret E85 PA/B/TiCN	RO Φ15
	1 Slot	PA/Thick Turret E85 PA/B/KPM	RO Φ15
	(0,90)	PA/Thick Turret E85 PA/B	RE 5*30
	(0,90)	PA/Thick Turret E85 PA/B/TiCN	RE 5*30
	(0,90)	PA/Thick Turret E85 PA/B/KPM	RE 5*30
	(0,90)	PA/Thick Turret E85 PA/B/(45)	RE 3*25
	(0,90)	PA/Thick Turret E85 PA/B/(90)	RE 4*30
	(0,90)	PA/Thick Turret E85 PA/B/(0,90)	SQ 15*15
	(0,90)	PA/Thick Turret E85 PA/B/(135)	RE 3*25
	(0,90)	PA/Thick Turret E85 PA/B/TiCN/(0,90)	SQ 15*15
	(0,90)	PA/Thick Turret E85 PA/B/KPM/(0,90)	SQ 10*10
	(0,135)	PA/Thick Turret E85 PA/B	SQ 15*15
	(0,135)	PA/Thick Turret E85 PA/B/TiCN	SQ 15*15
	(0,135)	PA/Thick Turret E85 PA/B/KPM	SQ 15*15
	(0,45,90)	PA/Thick Turret E85 PA/B/(0,45,90)	OB Φ8*16
	(0,90,180,270)	PA/Thick Turret E85 PA/B/(0,90,180,270)	Class A A10/A*B
	(0,90,180,270)	PA/Thick Turret E85 PA/B/TiCN/(0,90,180,270)	Class B B11/A*B
(0,90,180,270)	PA/Thick Turret E85 PA/B/KPM/(0,90,180,270)	Class C C5/A*B	
(0,90)	PA/Thick Turret E85 PA/B/Blanking	RE 5*30-0.3	

Item	Slot	Description	Size (e.g.)
11.1 Punch/Thick Turret 85 Punch			
	No Pin	Punch/Thick Turret 85 Punch/B	RO Φ15
	Pin	Punch/Thick Turret 85 Punch/B	RE 5*30
	Pin	Punch/Thick Turret 85 Punch/B/Blanking	SQ 15*15-0.2
	Pin	Punch/Thick Turret 85 Punch/B/TiCN	SQ 15*15
	Pin	Punch/Thick Turret 85 Punch/B/KPM	RE 5*30
	Pin	Punch/Thick Turret 85 Punch/B/(45)	RE 3*25
11.2 Guide/Thick Turret 85 Guide			
	1 Slot	Guide/Thick Turret 85 Guide/B	RO Φ15
	(0,90)	Guide/Thick Turret 85 Guide/B	RE 5*25
	(0,90)	Guide/Thick Turret 85 Guide/B/(45)	RE 3*25
	(0,90)	Guide/Thick Turret 85 Guide/B/(90)	RE 4*30
	(0,90)	Guide/Thick Turret 85 Guide/B/(0,90)	SQ 15*15
	(0,135)	Guide/Thick Turret 85 Guide/B/Blanking	SQ 15*15-0.2
	(0,45,90)	Guide/Thick Turret 85 Guide/B/(0,45,90)	OB Φ8*16
	(0,90,180,270)	Guide/Thick Turret 85 Guide/B/(0,90,180,270)	Class C FT/A*B
11.3 Punch Head Ass'y/Thick Turret E85 Punch Head Ass'y			
		PHA/Thick Turret E85 PHA/B	

E85 Light Duty	Slot	Description	Size (e.g.)
----------------	------	-------------	-------------

12# Punch Ass'y/Thick Turret E85 Light Duty Punch Ass'y			
	1 Slot	PA/Thick Turret E85 LD PA/B	RO Φ15
	1 Slot	PA/Thick Turret E85 LD PA/B/TiCN	RO Φ15
	1 Slot	PA/Thick Turret E85 LD PA/B/KPM	RO Φ15
	(0,90)	PA/Thick Turret E85 LD PA/B	RE 5*30
	(0,90)	PA/Thick Turret E85 LD PA/B/TiCN	RE 5*30
	(0,90)	PA/Thick Turret E85 LD PA/B/KPM	RE 5*30
	(0,90)	PA/Thick Turret E85 LD PA/B/(45)	RE 3*25
	(0,90)	PA/Thick Turret E85 LD PA/B/(90)	RE 4*30
	(0,90)	PA/Thick Turret E85 LD PA/B/(0,90)	SQ 15*15
	(0,90)	PA/Thick Turret E85 LD PA/B/(135)	RE 3*25
	(0,90)	PA/Thick Turret E85 LD PA/B/TiCN/(0,90)	SQ 15*15
	(0,90)	PA/Thick Turret E85 LD PA/B/KPM/(0,90)	SQ 10*10
	(0,135)	PA/Thick Turret E85 LD PA/B	SQ 15*15
	(0,135)	PA/Thick Turret E85 LD PA/B/TiCN	SQ 15*15
	(0,135)	PA/Thick Turret E85 LD PA/B/KPM	SQ 15*15
	(0,45,90)	PA/Thick Turret E85 LD PA/B/(0,45,90)	OB Φ8*16
	(0,90,180,270)	PA/Thick Turret E85 LD PA/B/(0,90,180,270)	Class A A5/A*B
(0,90,180,270)	PA/Thick Turret E85 LD PA/B/TiCN/(0,90,180,270)	Class B B2/ØD*A	
(0,90,180,270)	PA/Thick Turret E85 LD PA/B/KPM/(0,90,180,270)	Class C FT/A*B	

12.1 Punch/Thick Turret 85 Punch			
	No Pin	Punch/Thick Turret 85 Punch/B	RO Φ15
	Pin	Punch/Thick Turret 85 Punch/B	RE 5*30
	Pin	Punch/Thick Turret 85 Punch/B	SQ 15*15
	Pin	Punch/Thick Turret 85 Punch/B/TiCN	SQ 15*15
	Pin	Punch/Thick Turret 85 Punch/B/KPM	RE 5*30
	Pin	Punch/Thick Turret 85 Punch/B/(45)	RE 3*25
12.2 Guide/Thick Turret 85 Guide			
	1 Slot	Guide/Thick Turret 85 Guide/B	RO Φ15
	(0,90)	Guide/Thick Turret 85 Guide/B	RE 5*25
	(0,90)	Guide/Thick Turret 85 Guide/B/(45)	RE 3*25
	(0,90)	Guide/Thick Turret 85 Guide/B/(90)	RE 4*30
	(0,90)	Guide/Thick Turret 85 Guide/B/(0,90)	SQ 15*15
	(0,135)	Guide/Thick Turret 85 Guide/B	SQ 15*15
	(0,45,90)	Guide/Thick Turret 85 Guide/B/(0,45,90)	OB Φ8*16
	(0,90,180,270)	Guide/Thick Turret 85 Guide/B/(0,90,180,270)	Class C C6/A*B

12.3 Punch Head Ass'y/Thick Turret E85 Light Duty Punch Head Ass'y			
		PHA/Thick Turret E85 LD PHA/B	

*** LD: Light Duty
 *** TT: Thick Turret
 *** PA: Punch Ass'y
 *** PHA: Punch Head Ass'y
 *** KPM: KETEC Powder Material
 *** TiCN: Coating

B STN (Size Range:ΦD:12.71~31.7mm)

THICK TURRET
B STN

E80 B STN	Slot	Description	Size (e.g.)
-----------	------	-------------	-------------

13# Punch Ass'y/Thick Turret E80 Punch Ass'y



1 Slot	PHA/Thick Turret E80PHA/B	RO Φ15
1 Slot	PHA/Thick Turret E80PHA/B/TiCN	RO Φ15
1 Slot	PHA/Thick Turret E80PHA/B/KPM	RO Φ15
(0,90)	PHA/Thick Turret E80PHA/B	RE 5*30
(0,90)	PHA/Thick Turret E80PHA/B/TiCN	RE 5*30
(0,90)	PHA/Thick Turret E80PHA/B/KPM	RE 5*30
(0,90)	PHA/Thick Turret E80PHA/B/(45)	RE 3*25
(0,90)	PHA/Thick Turret E80PHA/B/(90)	RE 4*30
(0,90)	PHA/Thick Turret E80PHA/B/(0,90)	SQ 15*15
(0,90)	PHA/Thick Turret E80PHA/B/(135)	RE 3*25
(0,90)	PHA/Thick Turret E80PHA/B/TiCN/(0,90)	SQ 15*15
(0,90)	PHA/Thick Turret E80PHA/B/KPM/(0,90)	SQ 10*10
(0,135)	PHA/Thick Turret E80PHA/B	SQ 15*15
(0,135)	PHA/Thick Turret E80PHA/B/TiCN	SQ 15*15
(0,135)	PHA/Thick Turret E80PHA/B/KPM	SQ 15*15

13.1 Punch/Thick Turret 80 Punch



No Pin	Punch/Thick Turret 80 Punch/B	RO Φ15
--------	-------------------------------	--------



Pin	Punch/Thick Turret 80 Punch/B	RE 5*30
Pin	Punch/Thick Turret 80 Punch/B	SQ 15*15
Pin	Punch/Thick Turret 80 Punch/B/TiCN	SQ 15*15
Pin	Punch/Thick Turret 80 Punch/B/KPM	RE 5*30
Pin	Punch/Thick Turret 80 Punch/B/(45)	RE 3*25

13.2 Guide/Thick Turret 80 Guide



1 Slot	Guide/Thick Turret 80 Guide/B	
(0,90)	Guide/Thick Turret 80 Guide/B	
(0,135)	Guide/Thick Turret 80 Guide/B	

13.3 Punch Head Ass'y/Thick Turret E80 Punch Head Ass'y



	Punch Head Ass'y/Thick Turret E80Punch H	
--	--	--

13.4 Stripper/Thick Turret 80 Stripper

	Stripper/TT 80 Stripper/B	
--	---------------------------	--

14# Punch Ass'y/Thick Turret E80 Heavy Duty Punch Ass'y



1 Slot	PA/Thick Turret E80 Heavy Duty PA/B	RO Φ15
1 Slot	PA/Thick Turret E80 Heavy Duty PA/B/TiCN	RO Φ15
1 Slot	PA/Thick Turret E80 Heavy Duty PA/B/KPM	RO Φ15
(0,90)	PA/Thick Turret E80 Heavy Duty PA/B	RE 5*30
(0,90)	PA/Thick Turret E80 Heavy Duty PA/B/TiCN	RE 5*30
(0,90)	PA/Thick Turret E80 Heavy Duty PA/B/KPM	RE 5*30
(0,90)	PA/Thick Turret E80 Heavy Duty PA/B/(45)	RE 3*25
(0,90)	PA/Thick Turret E80 Heavy Duty PA/B/(90)	RE 4*30
(0,90)	PA/Thick Turret E80 Heavy Duty PA/B/(0,90)	SQ 15*15
(0,90)	PA/Thick Turret E80 Heavy Duty PA/B/(135)	RE 3*25
(0,90)	PA/Thick Turret E80 Heavy Duty PA/B/TiCN/(0,90)	SQ 15*15
(0,90)	PA/Thick Turret E80 Heavy Duty PA/B/KPM/(0,90)	SQ 10*10
(0,135)	PA/Thick Turret E80 Heavy Duty PA/B	SQ 15*15
(0,135)	PA/Thick Turret E80 Heavy Duty PA/B/TiCN	SQ 15*15
(0,135)	PA/Thick Turret E80 Heavy Duty PA/B/KPM	SQ 15*15

B STN (Size Range:ΦD:12.71~31.7mm)





THICK TURRET
B STN

Item	Slot	Description	Size(e.g.)
14.1 Punch/Thick Turret 80 Heavy Duty Punch			
	No Pin	Punch/Thick Turret 80 Heavy Duty Punch/B	RO Φ15
	Pin	Punch/Thick Turret 80 Heavy Duty Punch/B	RE 5*30
	Pin	Punch/Thick Turret 80 Heavy Duty Punch/B	SQ 15*15
	Pin	Punch/Thick Turret 80 Heavy Duty Punch/B/TiCN	SQ 15*15
	Pin	Punch/Thick Turret 80 Heavy Duty Punch/B/KPM	RE 5*30
	Pin	Punch/Thick Turret 80 Heavy Duty Punch/B/(45)	RE 3*25
14.2 Guide/Thick Turret 80 Guide			
	1 Slot	Guide/Thick Turret 80 Guide/B	
	(0,90)	Guide/Thick Turret 80 Guide/B	
	(0,135)	Guide/Thick Turret 80 Guide/B	
14.3 Punch Head Ass'y/Thick Turret E80 Heavy Duty Punch Head Ass'y		14.4 Stripper/Thick Turret 80 Stripper	
		PHA/Thick Turret E80 HD PHA/B	
15# Punch Ass'y/Thick Turret E80 Heavy Duty Special Height Punch Ass'y			
	1 Slot	PA/Thick Turret E80 HD SH PA/B	RO Φ15
	1 Slot	PA/Thick Turret E80 HD SH PA/B/TiCN	RO Φ15
	1 Slot	PA/Thick Turret E80 HD SH PA/B/KPM	RO Φ15
	(0,90)	PA/Thick Turret E80 HD SH PA/B	RE 5*30
	(0,90)	PA/Thick Turret E80 HD SH PA/B/TiCN	RE 5*30
	(0,90)	PA/Thick Turret E80 HD SH PA/B/KPM	RE 5*30
	(0,90)	PA/Thick Turret E80 HD SH PA/B/(45)	RE 3*25
	(0,90)	PA/Thick Turret E80 HD SH PA/B/(90)	RE 4*30
	(0,90)	PA/Thick Turret E80 HD SH PA/B/(0,90)	SQ 15*15
	(0,90)	PA/Thick Turret E80 HD SH PA/B/(135)	RE 3*25
	(0,90)	PA/Thick Turret E80 HD SH PA/B/TiCN/(0,90)	SQ 15*15
	(0,90)	PA/Thick Turret E80 HD SH PA/B/KPM/(0,90)	SQ 10*10
	(0,135)	PA/Thick Turret E80 HD SH PA/B	SQ 15*15
	(0,135)	PA/Thick Turret E80 HD SH PA/B/TiCN	SQ 15*15
	(0,135)	PA/Thick Turret E80 HD SH PA/B/KPM	SQ 15*15
15.1 Punch/Thick Turret 80 Heavy Duty Punch			
	No Pin	Punch/Thick Turret 80 Heavy Duty Punch/B	RO Φ15
	Pin	Punch/Thick Turret 80 Heavy Duty Punch/B	RE 5*30
	Pin	Punch/Thick Turret 80 Heavy Duty Punch/B	SQ 15*15
	Pin	Punch/Thick Turret 80 Heavy Duty Punch/B/TiCN	SQ 15*15
	Pin	Punch/Thick Turret 80 Heavy Duty Punch/B/KPM	RE 5*30
	Pin	Punch/Thick Turret 80 Heavy Duty Punch/B/(45)	RE 3*25
15.2 Guide/Thick Turret 80 Guide			
	1 Slot	Guide/Thick Turret 80 Guide/B	*** HD: Heavy Duty *** TT: Thick Turret *** PA: Punch Ass'y *** SH: Special Height *** PHA: Punch Head Ass'y *** KPM: KETEC Powder Material *** TiCN: Coating
	(0,90)	Guide/Thick Turret 80 Guide/B	
	(0,135)	Guide/Thick Turret 80 Guide/B	
15.3 Punch Head Ass'y/Thick Turret E80 Heavy Duty Special Height Punch Head Ass'y		15.4 Stripper/Thick Turret 80 Stripper	
		PHA/TT E80 Heavy Duty SH PHA/B	

B STN (Size Range:ΦD:12.71~31.7mm)

THICK TURRET
B STN

KU B STN	Slot	Description	Size (e.g.)	
16# Punch Ass'y/Thick Turret KU Punch Ass'y				
	1 Slot	PA/Thick Turret KU PA/B	RO Φ15	
	1 Slot	PA/Thick Turret KU PA/B/TiCN	RO Φ15	
	1 Slot	PA/Thick Turret KU PA/B/KPM	RO Φ15	
	(0,90)	PA/Thick Turret KU PA/B	RE 5*30	
	(0,90)	PA/Thick Turret KU PA/B/TiCN	RE 5*30	
	(0,90)	PA/Thick Turret KU PA/B/KPM	RE 5*30	
	(0,90)	PA/Thick Turret KU PA/B/(0,90)	SQ 15*15	
	(0,135)	PA/Thick Turret KU PA/B	SQ 15*15	
	(0,135)	PA/Thick Turret KU PA/B/TiCN/(0,135)	SQ 15*15	
	(0,135)	PA/Thick Turret KU PA/B/KPM/(0,135)	SQ 15*15	
	(0,135)	PA/Thick Turret KU PA/B/(0,135)	SQ 15*15	
16.1 Punch/Thick Turret KU Punch				
	Pin	Punch/Thick Turret KU Punch/B	RO Φ15	
	Pin	Punch/Thick Turret KU Punch/B/TiCN	SQ 15*15	
	Pin	Punch/Thick Turret KU Punch/B/KPM	RE 5*30	
	Pin	Punch/Thick Turret KU Punch/B	RE 5*30	
	Pin	Punch/Thick Turret KU Punch/B	SQ 15*15	
	Pin	Punch/Thick Turret KU Punch/B/TiCN	SQ 15*15	
		Punch/Thick Turret KU Punch/B/KPM	RE 5*30	
16.2 Guide/Thick Turret KU Guide				
	1 Slot	Guide/Thick Turret KU Guide/B		
	(0,90)	Guide/Thick Turret KU Guide/B/(0,90)		
	(0,135)	Guide/Thick Turret KU Guide/B/(0,135)		
16.3 Punch Head Ass'y/Thick Turret KU Punch Head Ass'y		16.4 Stripper/Thick Turret KU Stripper		
		PHA/Thick Turret KU PHA/B		
			Stripper/TT KU Stripper/B	

B STN Stripper	Description	Size (e.g.)
1# Stripper/Thick Turret 90 Stripper		
	Stripper/Thick Turret 90 Stripper/B	OB Φ3*30
	Stripper/Thick Turret 90 Stripper/B	RO Φ20
	Stripper/Thick Turret 90 Stripper/B	RE 5*30
	Stripper/Thick Turret 90 Stripper/B/Blanking	SQ 20*20-0.2
2# Stripper/Thick Turret 90 ABS Stripper		
	Stripper/Thick Turret 90 ABS Stripper/B	OB Φ3*30
	Stripper/Thick Turret 90 ABS Stripper/B	RO Φ20
	Stripper/Thick Turret 90 ABS Stripper/B	RE 5*30
	Stripper/Thick Turret 90 ABS Stripper/B/Blanking	SQ 20*20-0.2
3# Stripper/Thick Turret 80 Stripper		
	Stripper/Thick Turret 80 Stripper/B	OB Φ3*30
	Stripper/Thick Turret 80 Stripper/B	RO Φ20
	Stripper/Thick Turret 80 Stripper/B	RE 5*30
	Stripper/Thick Turret 80 Stripper/B	SQ 20*20
4# Stripper/Thick Turret KU Stripper		
	Stripper/Thick Turret KU Stripper/B	OB Φ3*30
	Stripper/Thick Turret KU Stripper/B	RO Φ20
	Stripper/Thick Turret KU Stripper/B	RE 5*30
	Stripper/Thick Turret KU Stripper/B/Blanking	SQ 20*20-0.2

B STN (Size Range:ΦD:12.71~31.7mm)

	Slot	Description	Size(e.g.)
1# Punch/Thick Turret 85 Punch			
	No Pin	Punch/Thick Turret 85 Punch/B	RO Φ15
	Pin	Punch/Thick Turret 85 Punch/B	RE 5*30
	Pin	Punch/Thick Turret 85 Punch/B/Blanking	SQ 15*15-0.2
	Pin	Punch/Thick Turret 85 Punch/B/TiCN	SQ 15*15
	Pin	Punch/Thick Turret 85 Punch/B/KPM	RE 5*30
	Pin	Punch/Thick Turret 85 Punch/B/(45)	RE 3*25
2# Punch/Thick Turret 85 ABS Punch			
	No Pin	Punch/Thick Turret 85 ABS Punch/B	RO Φ15
	Pin	Punch/Thick Turret 85 ABS Punch/B	RE 5*30
	Pin	Punch/Thick Turret 85 ABS Punch/B/Blanking	SQ 15*15-0.2
	Pin	Punch/Thick Turret 85 ABS Punch/B/TiCN	SQ 15*15
	Pin	Punch/Thick Turret 85 ABS Punch/B/KPM	RE 5*30
	Pin	Punch/Thick Turret 85 ABS Punch/B/(45)	RE 3*25
3# Punch/Thick Turret 85 Fully Guided Punch			
	No Pin	Punch/Thick Turret 85 Fully Guided Punch/B	
	Pin	Punch/Thick Turret 85 Fully Guided Punch/B	RE 5*30
	Pin	Punch/Thick Turret 85 Fully Guided Punch/B	SQ 15*15
	Pin	Punch/Thick Turret 85 Fully Guided Punch/B/TiCN	SQ 15*15
	Pin	Punch/Thick Turret 85 Fully Guided Punch/B/KPM	RE 5*30
	Pin	Punch/Thick Turret 85 Fully Guided Punch/B/(45)	RE 3*25
4# Punch/Thick Turret 85 ABS Fully Guided Punch			
	No Pin	Punch/Thick Turret 85 ABS Fully Guided Punch/B	
	Pin	Punch/Thick Turret 85 ABS Fully Guided Punch/B	RE 5*30
	Pin	Punch/Thick Turret 85 ABS Fully Guided Punch/B	SQ 15*15
	Pin	Punch/Thick Turret 85 ABS Fully Guided Punch/B/TiCN	SQ 15*15
	Pin	Punch/Thick Turret 85 ABS Fully Guided Punch/B/KPM	RE 5*30
	Pin	Punch/Thick Turret 85 ABS Fully Guided Punch/B/(45)	RE 3*25
5# Punch/Thick Turret 80 Punch			
	No Pin	Punch/Thick Turret 80 Punch/B	RO Φ15
	Pin	Punch/Thick Turret 80 Punch/B	RE 5*30
	Pin	Punch/Thick Turret 80 Punch/B	SQ 15*15
	Pin	Punch/Thick Turret 80 Punch/B/TiCN	SQ 15*15
	Pin	Punch/Thick Turret 80 Punch/B/KPM	RE 5*30
	Pin	Punch/Thick Turret 80 Punch/B/(45)	RE 3*25
6# Punch/Thick Turret 80 Heavy Duty Punch			
	No Pin	Punch/Thick Turret 80 Heavy Duty Punch/B	RO Φ15
	Pin	Punch/Thick Turret 80 Heavy Duty Punch/B	RE 5*30
	Pin	Punch/Thick Turret 80 Heavy Duty Punch/B	SQ 15*15
	Pin	Punch/Thick Turret 80 Heavy Duty Punch/B/TiCN	SQ 15*15
	Pin	Punch/Thick Turret 80 Heavy Duty Punch/B/KPM	RE 5*30
	Pin	Punch/Thick Turret 80 Heavy Duty Punch/B/(45)	RE 3*25
7# Punch/Thick Turret 90 Punch			
	No Pin	Punch/Thick Turret 90 Punch/B	RO Φ15
	Pin	Punch/Thick Turret 90 Punch/B	RE 5*30
	Pin	Punch/Thick Turret 90 Punch/B/Blanking	SQ 15*15-0.2
	Pin	Punch/Thick Turret 90 Punch/B/TiCN	SQ 15*15
	Pin	Punch/Thick Turret 90 Punch/B/KPM	RE 5*30
	Pin	Punch/Thick Turret 90 Punch/B/(45)	RE 3*25

THICK TURRET
B STN







B STN (Size Range:ΦD:12.71~31.7mm)

THICK TURRET
B STN

B STN Punch	Slot	Description	Size (e.g.)
8# Punch/Thick Turret 90 ABS Punch			
	No Pin	Punch/Thick Turret 90 ABS Punch/B	RO Φ15
	Pin	Punch/Thick Turret 90 ABS Punch/B	RE 5*30
	Pin	Punch/Thick Turret 90 ABS Punch/B	SQ 15*15
	Pin	Punch/Thick Turret 90 ABS Punch/B/TiCN	SQ 15*15
	Pin	Punch/Thick Turret 90 ABS Punch/B/KPM	RE 5*30
	Pin	Punch/Thick Turret 90 ABS Punch/B/(45)	RE 3*25
9# Punch/Thick Turret 90 Heavy Duty Punch			
	No Pin	Punch/Thick Turret 90 Heavy Duty Punch/B	RO Φ15
	Pin	Punch/Thick Turret 90 Heavy Duty Punch/B	RE 5*30
	Pin	Punch/Thick Turret 90 Heavy Duty Punch/B	SQ 15*15
	Pin	Punch/Thick Turret 90 Heavy Duty Punch/B/TiCN	SQ 15*15
	Pin	Punch/Thick Turret 90 Heavy Duty Punch/B/KPM	RE 5*30
	Pin	Punch/Thick Turret 90 Heavy Duty Punch/B/(45)	RE 3*25
10# Punch/Thick Turret KU Punch			
	Pin	Punch/Thick Turret KU Punch/B	RO Φ15
	Pin	Punch/Thick Turret KU Punch/B/TiCN	SQ 15*15
	Pin	Punch/Thick Turret KU Punch/B/KPM	RE 5*30
	Pin	Punch/Thick Turret KU Punch/B	RE 5*30
	Pin	Punch/Thick Turret KU Punch/B	SQ 15*15
	Pin	Punch/Thick Turret KU Punch/B/TiCN	SQ 15*15
	Pin	Punch/Thick Turret KU Punch/B/KPM	RE 5*30

B STN Guide	Slot	Description	Size (e.g.)
1# Guide/Thick Turret 85 Guide			
	1 Slot	Guide/Thick Turret 85 Guide/B	RO Φ15
	(0,90)	Guide/Thick Turret 85 Guide/B	RE 5*25
	(0,90)	Guide/Thick Turret 85 Guide/B/(45)	RE 3*25
	(0,90)	Guide/Thick Turret 85 Guide/B/(90)	RE 4*30
	(0,90)	Guide/Thick Turret 85 Guide/B/(0,90)	SQ 15*15
	(0,135)	Guide/Thick Turret 85 Guide/B/Blanking	SQ 15*15-0.2
	(0,45,90)	Guide/Thick Turret 85 Guide/B/(0,45,90)	OB Φ8*16
	(0,90,180,270)	Guide/Thick Turret 85 Guide/B/(0,90,180,270)	Key Hole C1/Ød*A
2# Guide/Thick Turret 85 Open Guide			
	1 Slot	Guide/Thick Turret 85 Open Guide/B	
	(0,90)	Guide/Thick Turret 85 Open Guide/B	
	(0,135)	Guide/Thick Turret 85 Open Guide/B	
3# Guide/Thick Turret 85 ABS Guide			
	1 Slot	Guide/Thick Turret 85 ABS Guide/B	RO Φ15
	(0,90)	Guide/Thick Turret 85 ABS Guide/B	RE 5*25
	(0,90)	Guide/Thick Turret 85 ABS Guide/B/(45)	RE 3*25
	(0,90)	Guide/Thick Turret 85 ABS Guide/B/(90)	RE 4*30
	(0,90)	Guide/Thick Turret 85 ABS Guide/B/(0,90)	SQ 15*15
	(0,135)	Guide/Thick Turret 85 ABS Guide/B/Blanking	SQ 15*15-0.2
	(0,90,180,270)	Guide/Thick Turret 85 ABS Guide/B/(0,90,180,270)	Class C FT/A*B
4# Guide/Thick Turret 85ABS Open Guide			
	1 Slot	Guide/Thick Turret 85 ABS Open Guide/B	
	(0,90)	Guide/Thick Turret 85 ABS Open Guide/B	
	(0,135)	Guide/Thick Turret 85 ABS Open Guide/B	

B STN (Size Range:ΦD:12.71~31.7mm)

B STN Guide	Slot	Description	Size(e.g.)
5# Guide/Thick Turret 85 Fully Guided Guide			
	(0,90)	Guide/Thick Turret 85 Fully Guided Guide/B	RO Φ15
	(0,90)	Guide/Thick Turret 85 Fully Guided Guide/B	RE 5*25
	(0,90)	Guide/Thick Turret 85 Fully Guided Guide/B/(45)	RE 3*25
	(0,90)	Guide/Thick Turret 85 Fully Guided Guide/B/(90)	RE 4*30
	(0,90)	Guide/Thick Turret 85 Fully Guided Guide/B/(0,90)	SQ 15*15
6# Guide/Thick Turret 85 ABS Fully Guided Guide			
	(0,90)	Guide/Thick Turret 85 ABS Fully Guided Guide/B	RO Φ15
	(0,90)	Guide/Thick Turret 85 ABS Fully Guided Guide/B	RE 5*25
	(0,90)	Guide/Thick Turret 85 ABS Fully Guided Guide/B/(45)	RE 3*25
	(0,90)	Guide/Thick Turret 85 ABS Fully Guided Guide/B/(90)	RE 4*30
	(0,90)	Guide/Thick Turret 85 ABS Fully Guided Guide/B/(0,90)	SQ 15*15
7# Guide/Thick Turret KU Guide			
	1 Slot	Guide/Thick Turret KU Guide/B	
	(0,90)	Guide/Thick Turret KU Guide/B/(0,90)	
	(0,135)	Guide/Thick Turret KU Guide/B/(0,135)	
8# Guide/Thick Turret 90 Guide			
	1 Slot	Guide/Thick Turret 90 Guide/B	
	(0,90)	Guide/Thick Turret 90 Guide/B	
	(0,135)	Guide/Thick Turret 90 Guide/B	
	(0,45,90)	Guide/Thick Turret 90 Guide/B/(0,45,90)	
	(0,90,180,270)	Guide/Thick Turret 90 Guide/B/(0,90,180,270)	
9# Guide/Thick Turret 90 ABS Guide			
	1 Slot	Guide/Thick Turret 90 ABS Guide/B	
	(0,90)	Guide/Thick Turret 90 ABS Guide/B	
	(0,135)	Guide/Thick Turret 90 ABS Guide/B	
	(0,45,90)	Guide/Thick Turret 90 ABS Guide/B/(0,45,90)	
	(0,90,180,270)	Guide/Thick Turret 90 ABS Guide/B/(0,90,180,270)	
10# Guide/Thick Turret 80 Guide			
	1 Slot	Guide/Thick Turret 80 Guide/B	
	(0,90)	Guide/Thick Turret 80 Guide/B	
	(0,135)	Guide/Thick Turret 80 Guide/B	

THICK TURRET B STN

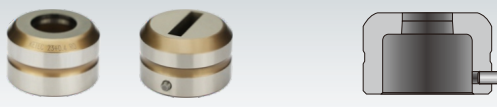
B STN Die	Pin	Description	Size (e.g.)
1# Die/Thick Turret Die			
	No Pin	Die/Thick Turret Die/B	RO Φ13.5+0.2
	No Pin	Die/Thick Turret Die/B	RO Φ13.7+1.2
	Pin	Die/Thick Turret Die/B	OB Φ6.5*14+0.2
	Pin	Die/Thick Turret Die/B	SQ 10*10+0.3
	Pin	Die/Thick Turret Die/B	Class C C6/A*B+1.2

*** ABS: ABS

B STN (Size Range:ΦD:12.71~31.7mm)

THICK TURRET
B STN

B STN Die	Slot	Description	Size (e.g.)
2# Die/Thick Turret Die/slughugger			
	No Pin	Die/Thick Turret Die/B	RO Φ13.5+0.2/slughugger-1
	No Pin	Die/Thick Turret Die/B	RO Φ13.7+1.2/slughugger-1
	Pin	Die/Thick Turret Die/B	OB Φ6.5*14+0.2/slughugger
	Pin	Die/Thick Turret Die/B	SQ 10*10+0.3/slughugger
	Pin	Die/Thick Turret Die/B	Class C FT/A*B+1.2/slughugger
3# Die/Thick Turret Vaccum Die			
	No Pin	Die/Thick Turret Vaccum Die/B	RO Φ13.5+0.2
	No Pin	Die/Thick Turret Vaccum Die/B	RO Φ13.7+1.2
	Pin	Die/Thick Turret Vaccum Die/B	OB Φ6.5*14+0.2
	Pin	Die/Thick Turret Vaccum Die/B	SQ 10*10+0.3
	Pin	Die/Thick Turret Vaccum Die/B	Class C FT/A*B+1.2
4# Die/Thick Turret Heavy Duty Die			
	No Pin	Die/Thick Turret Heavy Duty Die/B	RO Φ13.5+0.2
	No Pin	Die/Thick Turret Heavy Duty Die/B	RO Φ13.7+1.2
	Pin	Die/Thick Turret Heavy Duty Die/B	OB Φ6.5*14+0.2
	Pin	Die/Thick Turret Heavy Duty Die/B	SQ 10*10+0.3
	Pin	Die/Thick Turret Heavy Duty Die/B	Class C FT/A*B+1.2
5# Die/Thick Turret Die/Blanking			
	No Pin	Die/Thick Turret Die/B/Blanking	RO Φ15
	No Pin	Die/Thick Turret Die/B/Blanking	RO Φ25
	Pin	Die/Thick Turret Die/B/Blanking	RE 10*20
	Pin	Die/Thick Turret Die/B/Blanking	SQ 15*15
	Pin	Die/Thick Turret Die/B/Blanking	OB Φ10*20
6# Die/Thick Turret Special Die			
	No Pin	Die/Thick Turret Blank Die/B	
	No Pin	Die/Thick Turret Roller Die/B	
	No Pin	Die/Thick Turret Brush Die/B	

B STN Punch Head Ass'y		B STN Punch Head Ass'y	
1# Punch Head Ass'y/Thick Turret T85 Punch Head Ass'y	PHA/Thick Turret T85 PHA/B	2# Punch Head Ass'y/Thick Turret T85 Light Pack Punch Head Ass'y	PHA/Thick Turret T85 LP PHA/B
			
3# Punch Head Ass'y/Thick Turret T90 Punch Head Ass'y	PHA/Thick Turret T90 PHA/B	4# Punch Head Ass'y/Thick Turret T90 Heavy Duty Punch Head Ass'y	PHA/Thick Turret T90 Heavy Duty PHA/B
			
5# Punch Head Ass'y/Thick Turret KU Punch Head Ass'y	PHA/Thick Turret KU PHA/B	6# Punch Head Ass'y/Thick Turret E85 Punch Head Ass'y	PHA/Thick Turret E85 PHA/B
			
7# Punch Head Ass'y/Thick Turret E85 Light Punch Head Ass'y	PHA/Thick Turret E85 LP PHA/B	8# Punch Head Ass'y/Thick Turret E80 Punch Head Ass'y	PHA/Thick Turret E80 PHA/B
			
9# Punch Head Ass'y/Thick Turret E80 Heavy Duty Punch Head Ass'y	PHA/Thick Turret E80 HD PHA/B	10# Punch Head Ass'y/Thick Turret E80 Heavy Duty SH Punch Head Ass'y	PHA/Thick Turret E80HD SH PHA/B
			

C STN (Size Range:ΦD:31.71 ~50.8mm)

T85 C STN	Slot	Description	Size(e.g.)	
1# Punch Ass'y/Thick Turret T85 Punch Ass'y				
	3 Slots	PA/TT T85 PA/C	RE 5*50	
	3 Slots	PA/TT T85 PA/C	OB Φ5*50/Rooftop	
	3 Slots	PA/TT T85 PA/C	RO Φ40	
	3 Slots	PA/TT T85 PA/C	SQ 35*35/Rooftop	
	3 Slots	PA/TT T85 PA/C	HX A=S=33	
	3 Slots	PA/TT T85 PA/C	Ellipse/A*B*R	
	3 Slots	PA/TT T85 PA/C	One Way Radius B8/A*B*R	
	3 Slots	PA/TT T85 PA/C/TiCN	Class C FT/A*B	
	3 Slots	PA/TT T85 PA/C/TiCN	SQ 30*30	
	3 Slots	PA/TT T85 PA/C/TiCN	RE 5*50	
	3 Slots	PA/TT T85 PA/C/TiCN	OB Φ5*50	
	3 Slots	PA/TT T85 PA/C/19 Type/C	RE 5*50	
	3 Slots	PA/TT T85 PA/C/19 Type/C	RE 5*50/Rooftop	
	3 Slots	PA/TT T85 PA/C/19 Type/C/KPM	RE 5*50	
	3 Slots	PA/TT T85 PA/C/19 Type/C/TiCN	RE 5*50	
3 Slots	PA/TT T85 PA/C/Blanking	RO Φ40-0.2		
1.1# Punch/Thick Turret 85 Punch				
	1 Slot	Punch/Thick Turret 85 Punch/C	RO Φ35	
	1 Slot	Punch/Thick Turret 85 Punch/C	RE 5*50	
	1 Slot	Punch/Thick Turret 85 Punch/C	RE 5*50/Rooftop	
	1 Slot	Punch/Thick Turret 85 Punch/C(45)	RE 5*40	
	1 Slot	Punch/Thick Turret 85 Punch/C/TiCN	RE 5*50	
	1 Slot	Punch/Thick Turret 85 Punch/C/TiCN	SQ 30*30	
	1 Slot	Punch/Thick Turret 85 Punch/C/DF	OB Φ5*50	
	2 Slots	Punch/Thick Turret 85 Punch/C/(0,180)	Class C C10/A*B	
	2 Slots	Punch/TT 85 Punch/C/TiCN/(0,180)	Class C FT/A*B	
	1 Slot	Punch/TT 85 Punch/C/Blanking	RE 5*50-0.2	
1.2# Punch/Thick Turret 85 Slitting Punch/19 Type				
	1 Slot	Punch/TT 85 Slitting Punch/19 T/C	RE 5*50	
	1 Slot	Punch/TT 85 Slitting Punch/19 T/C	OB Φ5*50	
	1 Slot	Punch/TT 85 Slitting Punch/19 T/C/KPM	RE 5*50	
	1 Slot	Punch/TT 85 Slitting Punch/19 T/C/KPM	OB Φ5*50	
	1 Slot	Punch/TT 85 Slitting Punch/19 T/C/TiCN	RE 5*50	
	1 Slot	Punch/TT 85 Slitting Punch/19 T/C/TiCN	OB Φ5*50	
	1 Slot	Punch/TT 85 Slitting Punch/19 T/C/DF	RE 5*50	
	1 Slot	Punch/TT 85 Slitting Punch/19 T/C/C/DF	OB Φ5*50	
	1.3# Stripper/Thick Turret 85 Stripper			
		Stripper/Thick Turret 85 Stripper/C	RO Φ35	
Stripper/Thick Turret 85 Stripper/C		RE 5*50		
Stripper/Thick Turret 85 Stripper/C		OB Φ5*50		
Stripper/Thick Turret 85 Stripper/C		SQ 30*30		
Stripper/Thick Turret 85 Stripper/C		HX S=33		
Stripper/Thick Turret 85 Stripper/C		Class A /A*B		
Stripper/Thick Turret 85 Stripper/C		Class B17/A*B		
Stripper/Thick Turret 85 Stripper/C		Class C FT/A*B		
Stripper/Thick Turret 85 Stripper/C/Blanking		RE 5*50-0.2		

THICK TURRET C STN



1.4# Guide Ass'y/T85 Guide Ass'y/C 1.5# Guide/Thick Turret 90 Guide/C/(0,90,225) 1.6# PHA/Thick Turret T85 PHA/C

*** DF: Deep Freeze *** KPM: KETEC Powder Material *** TT: Thick Turret *** PHA: Punch Head Ass'y *** TiCN: Coating

C STN (Size Range:ΦD:31.71~50.8mm)

THICK TURRET C STN

T85 ABS C STN	Slot	Description	Size (e.g.)
2# Punch Ass'y/Thick Turret T85 ABS Punch Ass'y			
	3 Slots	PA/TT T85 ABS PA/C	RE 5*50
	3 Slots	PA/TT T85 ABS PA/C	OB Φ5*50/Rooftop
	3 Slots	PA/TT T85 ABS PA/C	RO Φ40
	3 Slots	PA/TT T85 ABS PA/C	SQ 35*35/Rooftop
	3 Slots	PA/TT T85 ABS PA/C	HX A=S=33
	3 Slots	PA/TT T85 ABS PA/C	Class C FT/A*B
	3 Slots	PA/TT T85 ABS PA/C	Class C FT/A*B
	3 Slots	PA/TT T85 ABS PA/C/TiCN	Class C FT/A*B
	3 Slots	PA/TT T85 ABS PA/C/TiCN	SQ 30*30
	3 Slots	PA/TT T85 ABS PA/C/TiCN	RE 5*50
	3 Slots	PA/TT T85 ABS PA/C/TiCN	OB Φ5*50
	3 Slots	PA/TT T85 ABS PA/C/Blanking	RE 5*50-0.2
	2.1# Punch/Thick Turret 85 ABS Punch		
	1 Slot	Punch/TT 85 ABS Punch/C	RO Φ35
	1 Slot	Punch/TT 85 ABS Punch/C	RE 5*50
	1 Slot	Punch/TT 85 ABS Punch/C	RE 5*50/Rooftop
	1 Slot	Punch/TT 85 ABS Punch/C(45)	RE 5*40
	1 Slot	Punch/TT 85 ABS Punch/C/TiCN	RE 5*50
	1 Slot	Punch/TT 85 ABS Punch/C/TiCN	SQ 30*30
	1 Slot	Punch/TT 85 ABS Punch/C/DF	OB Φ5*50
	2 Slots	Punch/TT 85 ABS Punch/C/(0, 180)	Class C FT/A*B
	2 Slots	Punch/TT 85 ABS Punch/C/TiCN/(0, 180)	Class C FT/A*B
	1 Slot	Punch/TT 85 ABS Punch/C/Blanking	RE 5*50-0.2
2.2# Stripper/Thick Turret 85 ABS Stripper			
	Stripper/TT 85 ABS Stripper/C		RO Φ35
	Stripper/TT 85 ABS Stripper/C		RE 5*50
	Stripper/TT 85 ABS Stripper/C		OB Φ5*50
	Stripper/TT 85 ABS Stripper/C		SQ 30*30
	Stripper/TT 85 ABS Stripper/C		HX A=S=33
	Stripper/TT 85 ABS Stripper/C		HX A9/A*B
	Stripper/TT 85 ABS Stripper/C		Semi Circle B21/A*B
	Stripper/TT 85 ABS Stripper/C		Key Hole C1/Ød*A
	Stripper/TT 85 ABS Stripper/C/Blanking		RE 5*50-0.2



2.3# Guide Ass'y/TT T85 ABS Guide Ass'y/C 2.4# Guide/TT T90 Guide/C (0,90,225) 2.5# PHA/TT T85 ABS PHA/C

C STN (Size Range:ΦD:31.71 ~ 50.80mm)

T85 Fully Guided C STN	Slot	Description	Size(e.g.)
3# Punch Ass'y/Thick Turret T85 Fully Guided Punch Ass'y			
	2 Slots	PA/TT T85 Fully Guided PA/C	RE 5*50
	2 Slots	PA/TT T85 Fully Guided PA/C	OB Φ5*50/Rooftop
	2 Slots	PA/TT T85 Fully Guided PA/C	RO Φ40
	2 Slots	PA/TT T85 Fully Guided PA/C	SQ 35*35/Rooftop
	2 Slots	PA/TT T85 Fully Guided PA/C	HX A=S=33
	2 Slots	PA/TT T85 Fully Guided PA/C	Class C FT/A*B
	2 Slots	PA/TT T85 Fully Guided PA/C	One Way Radius B8/A*B*R
	2 Slots	PA/TT T85 Fully Guided PA/C/TiCN	Four Way Radius C11/A*B
	2 Slots	PA/TT T85 Fully Guided PA/C/TiCN	SQ 30*30
	2 Slots	PA/TT T85 Fully Guided PA/C/TiCN	RE 5*50
	2 Slots	PA/TT T85 Fully Guided PA/C/TiCN	OB Φ5*50
	2 Slots	PA/TT T85 Fully Guided PA/19 Type/C	RE 5*50
	2 Slots	PA/TT T85 Fully Guided PA/19 Type/C	RE 5*50/Rooftop
	2 Slots	PA/TT T85 Fully Guided PA/19/C/KPM	RE 5*50
2 Slots	PA/TT T85 Fully Guided PA/19/C/TiCN	RE 5*50	
3.1# Punch/Thick Turret 85 Punch			
	1 Slot	Punch/Thick Turret 85Punch/C	RO Φ35
	1 Slot	Punch/Thick Turret 85Punch/C	RE 5*50
	1 Slot	Punch/Thick Turret 85Punch/C	RE 5*50/Rooftop
	1 Slot	Punch/Thick Turret 85Punch/C(45)	RE 5*40
	1 Slot	Punch/Thick Turret 85Punch/C/TiCN	RE 5*50
	1 Slot	Punch/Thick Turret 85Punch/C/TiCN	SQ 30*30
	1 Slot	Punch/Thick Turret 85Punch/C/DF	OB Φ5*50
	2 Slots	Punch/Thick Turret 85Punch/C/(0,180)	Class C FT/A*B
	2 Slots	Punch/Thick Turret 85Punch/C/TiCN/(0,180)	Class C FT/A*B
	3.2# Punch/Thick Turret 85 Slitting Punch/19 Type		
	1 Slot	Punch/TT 85 Slitting Punch/19 T/C	RE 5*50
	1 Slot	Punch/TT 85 Slitting Punch/19 T/C	RE 5*50/Rooftop
	1 Slot	Punch/TT 85 Slitting Punch/19 T/C/KPM	OB Φ5*50
	1 Slot	Punch/TT 85 Slitting Punch/19 T/C/KPM	RE 5*50
	1 Slot	Punch/TT 85 Slitting Punch/19 T/C/TiCN	OB Φ5*50
	1 Slot	Punch/TT 85 Slitting Punch/19 T/C/TiCN	RE 5*50
	1 Slot	Punch/TT 85 Slitting Punch/19 T/C/DF	OB Φ5*50
	1 Slot	Punch/TT 85 Slitting Punch/19 T/C/DF	RE 5*50
3.3# Stripper/Thick Turret 85 Fully Guided Stripper			
	Stripper/TT 85 Fully Guided Stripper/C	RO Φ35	
	Stripper/TT 85 Fully Guided Stripper/C	RE 5*50	
	Stripper/TT 85 Fully Guided Stripper/C	OB Φ5*50	
	Stripper/TT 85 Fully Guided Stripper/C	SQ 30*30	
	Stripper/TT 85 Fully Guided Stripper/C	HX A=S=33	
	Stripper/TT 85 Fully Guided Stripper/C	Class A A1/A*B	
	Stripper/TT 85 Fully Guided Stripper/C	Class B B2/ØD*A	
	Stripper/TT 85 Fully Guided Stripper/C	Class C FT/A*B	

THICK TURRET C STN





3.4# GA/TT T85 Fully Guided Guide Ass'y/C 3.5# Guide/TT 85 Fully Guided Guide/C/(0,90) 3.6# PHA/TT T85 PHA/C

C STN (Size Range:ΦD:31.71~50.8mm)

T85 HL Light Duty	Slot	Description	Size (e.g.)
-------------------	------	-------------	-------------

4# Punch Ass'y/Thick Turret HL 85 Light Duty Punch Ass'y			
 <p>Light Duty (Blue)</p> <p>Middle Duty (Red)</p> <p>Heavy Duty (Green)</p>	3 Slots	PA/TT HL 85 Light Duty PA/C	RE 5*50
	3 Slots	PA/TT HL 85 Light Duty PA/C	OB Φ5*50/Rooftop
	3 Slots	PA/TT HL 85 Light Duty PA/C	RO Φ40
	3 Slots	PA/TT HL 85 Light Duty PA/C	SQ 35*35/Rooftop
	3 Slots	PA/TT HL 85 Light Duty PA/C	HX S=33
	3 Slots	PA/TT HL 85 Light Duty PA/C	Class A A8/A*B
	3 Slots	PA/TT HL 85 Light Duty PA/C	RO 1 SlotB2/ØD*A
	3 Slots	PA/TT HL 85 Light Duty PA/C	Class C C7/A*B
	3 Slots	PA/TT HL 85 Light Duty PA/C	SQ 30*30
	3 Slots	PA/TT HL 85 Light Duty PA/C/TiCN	RE 5*50
	3 Slots	PA/TT HL 85 Light Duty PA/C/TiCN	OB Φ5*50
	3 Slots	PA/TT HL 85 Light Duty PA/C 19 T/C	RE 5*50
	3 Slots	PA/TT HL 85 Light Duty PA/C 19 T/C	RE 5*50/Rooftop
	3 Slots	PA/TT HL 85 Light Duty PA/C 19 T/C/KPM	RE 5*50
3 Slots	PA/TT HL 85 Light Duty PA/C 19 T/C/TiCN	RE 5*50	

4.1# Punch/Thick Turret 85 Punch			
	1 Slot	Punch/TT 85 Punch/C	RO Φ35
	1 Slot	Punch/TT 85 Punch/C	RE 5*50
	1 Slot	Punch/TT 85 Punch/C	RE 5*50/Rooftop
	1 Slot	Punch/TT 85 Punch/C(45)	RE 5*40
	1 Slot	Punch/TT 85 Punch/C/TiCN	RE 5*50
	1 Slot	Punch/TT 85 Punch/C/TiCN	SQ 30*30
	1 Slot	Punch/TT 85 Punch/C/DF	OB Φ5*50
	2 Slots	Punch/TT 85 Punch/C/(0,180)	Class BFT/A*B
	2 Slots	Punch/TT 85 Punch/C/TiCN/(0,180)	Class C FT/A*B

4.2# Punch/Thick Turret 85 Slitting Punch/19 T			
	1 Slot	Punch/TT 85 Slitting Punch/19 T/C	RE 5*50
	1 Slot	Punch/TT 85 Slitting Punch/19 T/C	OB Φ5*50
	1 Slot	Punch/TT 85 Slitting Punch/19 T/C/KPM	RE 5*50
	1 Slot	Punch/TT 85 Slitting Punch/19 T/C/KPM	OB Φ5*50
	1 Slot	Punch/TT 85 Slitting Punch/19 T/C/TiCN	RE 5*50
	1 Slot	Punch/TT 85 Slitting Punch/19 T/C/TiCN	OB Φ5*50
	1 Slot	Punch/TT 85 Slitting Punch/19 T/C/DF	RE 5*50
	1 Slot	Punch/TT 85 Slitting Punch/19 T/C/DF	OB Φ5*50

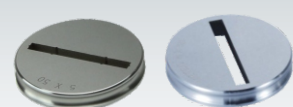
4.3# Stripper/Thick Turret 85 Stripper			
	Stripper/Thick Turret 85 Stripper/C		RO Φ35
	Stripper/Thick Turret 85 Stripper/C		RE 5*50
	Stripper/Thick Turret 85 Stripper/C		OB Φ5*50
	Stripper/Thick Turret 85 Stripper/C		SQ 30*30
	Stripper/Thick Turret 85 Stripper/C		HX S=33
	Stripper/Thick Turret 85 Stripper/C		Class A A12/A*B
	Stripper/Thick Turret 85 Stripper/C		Class B B7/A*B*R
	Stripper/Thick Turret 85 Stripper/C		Class C C4/ØD*A



4.4# GA/TT HL 85 Light Duty GA/C 4.5# Guide/Thick Turret 90Guide/C/(0,90,225) 4.6# PHA/TT HL 85 Light Duty PHA/C

THICK TURRET
C STN

C STN (Size Range:ΦD:31.7~31.7mm)

T90 C STN	Slot	Description	Size(e.g.)
5# Punch Ass'y/Thick Turret T90 Punch Ass'y			
	3 Slots	PA/Thick Turret T90 PA/C	RE 5*50
	3 Slots	PA/Thick Turret T90 PA/C	OB Φ5*50/Rooftop
	3 Slots	PA/Thick Turret T90 PA/C	RO Φ40
	3 Slots	PA/Thick Turret T90 PA/C	SQ 35*35/Rooftop
	3 Slots	PA/Thick Turret T90 PA/C	HX S=33
	3 Slots	PA/Thick Turret T90 PA/C	Class A A4/A*B
	3 Slots	PA/Thick Turret T90 PA/C	Class B B6/ØD*A
	3 Slots	PA/Thick Turret T90 PA/C/TiCN	Class C FT/A*B
	3 Slots	PA/Thick Turret T90 PA/C/TiCN	SQ 30*30
	3 Slots	PA/Thick Turret T90 PA/C/TiCN	RE 5*50
	3 Slots	PA/Thick Turret T90 PA/C/TiCN	OB Φ5*50
	3 Slots	PA/Thick Turret T90 PA/C/Blanking	RE 5*50-0.2
	5.1# Punch/Thick Turret 90 Punch		
	Pin	Punch/Thick Turret 90 Punch/C	RO Φ35
	Pin	Punch/Thick Turret 90 Punch/C	RE 5*50
	Pin	Punch/Thick Turret 90 Punch/C	RE 5*50/Rooftop
	Pin	Punch/Thick Turret 90 Punch/C (45)	RE 5*40
	Pin	Punch/Thick Turret 90 Punch/C/TiCN	RE 5*50
	Pin	Punch/Thick Turret 90 Punch/C/TiCN	SQ 30*30
	Pin	Punch/Thick Turret 90 Punch/C/DF	OB Φ5*50
	Pin	Punch/TT 90 Punch/C/Blanking	RE 5*50-0.2
5.2# Stripper/Thick Turret 90 Stripper			
	Stripper/Thick Turret 90 Stripper/C	RO Φ35	
	Stripper/Thick Turret 90 Stripper/C	RE 5*50	
	Stripper/Thick Turret 90 Stripper/C	OB Φ5*50	
	Stripper/Thick Turret 90 Stripper/C	SQ 30*30	
	Stripper/Thick Turret 90 Stripper/C	HX S=33	
	Stripper/Thick Turret 90 Stripper/C	Class A/A*B	
	Stripper/Thick Turret 90 Stripper/C	Class B B6/ØD*A	
	Stripper/Thick Turret 90 Stripper/C	Class C FT/A*B	
	Stripper/TT 90 Stripper/C/Blanking	RE 5*50-0.2	

THICK TURRET C STN



5.3# Guide Ass'y/Thick Turret T90 Guide Ass'y/C



5.4# Guide/TT 90 Guide/C/(0,90,225)





5.5# PHA/TT T90 PHA/C

C STN (Size Range:ΦD:31.71~50.8mm)

THICK TURRET
C STN

T90 ABS Punch Ass'y	Slot	Description	Size (e.g.)
---------------------	------	-------------	-------------

6# Punch Ass'y/Thick Turret T90 ABS Punch Ass'y			
	3 Slots	PA/Thick Turret T90 ABS PA/C	RE 5*50
	3 Slots	PA/Thick Turret T90 ABS PA/C	OB Φ5*50/Rooftop
	3 Slots	PA/Thick Turret T90 ABS PA/C	RO Φ40
	3 Slots	PA/Thick Turret T90 ABS PA/C	SQ 35*35/Rooftop
	3 Slots	PA/Thick Turret T90 ABS PA/C	HX S=33
	3 Slots	PA/Thick Turret T90 ABS PA/C	Class A /A*B
	3 Slots	PA/Thick Turret T90 ABS PA/C	RO 1 SlotB2/ØD*A
	3 Slots	PA/Thick Turret T90 ABS PA/C/TiCN	Class C C4/ØD*A
	3 Slots	PA/Thick Turret T90 ABS PA/C/TiCN	SQ 30*30
	3 Slots	PA/Thick Turret T90 ABS PA/C/TiCN	RE 5*50
	3 Slots	PA/Thick Turret T90 ABS PA/C/TiCN	OB Φ5*50

6.1# Punch/Thick Turret 90 Punch			
	Pin	Punch/Thick Turret 90 Punch/C	RO Φ35
	Pin	Punch/Thick Turret 90 Punch/C	RE 5*50
	Pin	Punch/Thick Turret 90 Punch/C	RE 5*50/Rooftop
	Pin	Punch/Thick Turret 90 Punch/C(45)	RE 5*40
	Pin	Punch/Thick Turret 90 Punch/C/TiCN	RE 5*50
	Pin	Punch/Thick Turret 90 Punch/C/TiCN	SQ 30*30
	Pin	Punch/Thick Turret 90 Punch/C/DF	OB Φ5*50

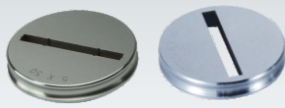
6.2# Stripper/Thick Turret 90 ABS Stripper			
	Stripper/Thick Turret 90 ABS Stripper/C	RO Φ35	
	Stripper/Thick Turret 90 ABS Stripper/C	RE 5*50	
	Stripper/Thick Turret 90 ABS Stripper/C	OB Φ5*50	
	Stripper/Thick Turret 90 ABS Stripper/C	SQ 30*30	
	Stripper/Thick Turret 90 ABS Stripper/C	HX S=33	
	Stripper/Thick Turret 90 ABS Stripper/C	Class A A8/A*B	
	Stripper/Thick Turret 90 ABS Stripper/C	RO 4 SlotsB5/ØD*A	
	Stripper/Thick Turret 90 ABS Stripper/C	Class C FT/A*B	



6.3# Guide Ass'y/TT T90 ABS Guide Ass'y/C 6.4# Guide/Thick Turret 90 Guide/C/(0,90,225) 6.5# PHA/TT T90 Punch Head Ass'y/C

C STN (Size Range:ΦD:31.71 ~ 50.8mm)

E85 C STN	Slot	Description	Size(e.g.)
-----------	------	-------------	------------

7# Punch Ass'y/Thick Turret E85 Punch Ass'y



2 Slots	PA/Thick Turret E85 PA/C	RE 5*50
2 Slots	PA/Thick Turret E85 PA/C	OB Φ5*50/Rooftop
2 Slots	PA/Thick Turret E85 PA/C/Blanking	RO Φ40-0.2
2 Slots	PA/Thick Turret E85 PA/C	SQ 35*35/Rooftop
2 Slots	PA/Thick Turret E85 PA/C	HX S=33
2 Slots	PA/Thick Turret E85 PA/C	Class A A15/A*B
2 Slots	PA/Thick Turret E85 PA/C	Class B B8/A*B*R
2 Slots	PA/Thick Turret E85 PA/C/TiCN	Class C C10/A*B
2 Slots	PA/Thick Turret E85 PA/C/TiCN	SQ 30*30
2 Slots	PA/Thick Turret E85 PA/C/TiCN	RE 5*50
2 Slots	PA/Thick Turret E85 PA/C/TiCN	OB Φ5*50
2 Slots	PA/Thick Turret E85 PA/19 T/C	RE 5*50
2 Slots	PA/Thick Turret E85 PA/19 T/C	RE 5*50/Rooftop
2 Slots	PA/Thick Turret E85 PA/19 T/C/KPM	RE 5*50
2 Slots	PA/Thick Turret E85 PA/19 T/C/TiCN	RE 5*50
3 Slots	PA/TT E85 PA/19 T/C/(0,90,135)	RE 5*50
4 Slots	PA/TT E85 PA/19 T/C/(0,90,180,270)	RE 5*50

7.1# Punch/Thick Turret 85 Punch



1 Slot	Punch/TT 85 Punch/C	RO Φ35
1 Slot	Punch/TT 85 Punch/C/Blanking	RE 5*50-0.2
1 Slot	Punch/TT 85 Punch/C	RE 5*50/Rooftop
1 Slot	Punch/TT 85 Punch/C(45)	RE 5*40
1 Slot	Punch/TT 85 Punch/C/TiCN	RE 5*50
1 Slot	Punch/TT 85 Punch/C/TiCN	SQ 30*30
1 Slot	Punch/TT 85 Punch/C/DF	OB Φ5*50
2 Slots	Punch/TT 85 Punch/C/(0,180)	Class A/A
2 Slots	Punch/TT 85 Punch/C/TiCN/(0,180)	Class B B13/A*B

7.2# Punch/Thick Turret 85 Slitting Punch/19 Type

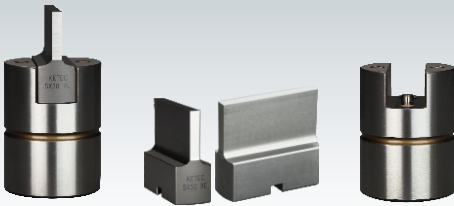

1 Slot	Punch/TT 85 Slitting Punch/19 T/C	RE 5*50
1 Slot	Punch/TT 85 Slitting Punch/19 T/C	OB Φ5*50
1 Slot	Punch/TT 85 Slitting Punch/19 T/C/KPM	RE 5*50
1 Slot	Punch/TT 85 Slitting Punch/19 T/C/KPM	OB Φ5*50
1 Slot	Punch/TT 85 Slitting Punch/19 T/C/TiCN	RE 5*50
1 Slot	Punch/TT 85 Slitting Punch/19 T/C/TiCN	OB Φ5*50
1 Slot	Punch/TT 85 Slitting Punch/19 T/C/DF	RE 5*50
1 Slot	Punch/TT 85 Slitting Punch/19 T/C/DF	OB Φ5*50

7.3# Stripper/Thick Turret 85 Stripper

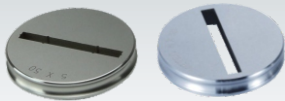

Stripper/Thick Turret 85 Stripper/C	RO Φ35
Stripper/Thick Turret 85 Stripper/C/Blanking	RE 5*50-0.2
Stripper/Thick Turret 85 Stripper/C	OB Φ5*50
Stripper/Thick Turret 85 Stripper/C	SQ 30*30
Stripper/Thick Turret 85 Stripper/C	HX S=33
Stripper/Thick Turret 85 Stripper/C	Class A A11/A*B
Stripper/Thick Turret 85 Stripper/C	Class B B8/A*B*R
Stripper/Thick Turret 85 Stripper/C	Class C FT/A*B

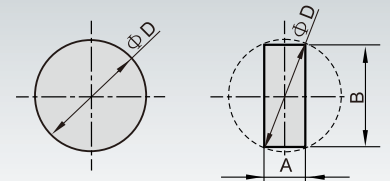

CSTN Size Range ΦD Minimum31.71mm;Maximum50.8mm

7.4# Guide Ass'y/Thick Turret E85 Guide Ass'y/C





7.5# Guide/Thick Turret 85 Guide/C/(0,90)

C STN (Size Range:ΦD:31.71~50.8mm)

THICK TURRET
C STN

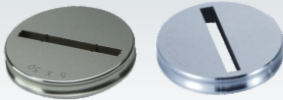
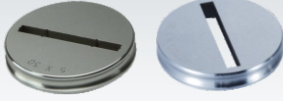
C STN Punch	Slot	Description	Size (e.g.)
1# Punch/Thick Turret 85 Punch			
	1 Slot	Punch/TT 85 Punch/C	RO Φ35
	1 Slot	Punch/TT 85 Punch/C/Blanking	RE 5*50-0.2
	1 Slot	Punch/TT 85 Punch/C	RE 5*50/Rooftop
	1 Slot	Punch/TT 85 Punch/C (45)	RE 5*40
	1 Slot	Punch/TT 85 Punch/C/TiCN	RE 5*50
	1 Slot	Punch/TT 85 Punch/C/TiCN	SQ 30*30
	1 Slot	Punch/TT 85 Punch/C/DF	OB Φ5*50
	2 Slots	Punch/TT 85 Punch/C/(0,180)	Class C FT/A*B
	2 Slots	Punch/TT 85 Punch/C/TiCN/(0,180)	Class C10/A*B
2# Punch/Thick Turret 90 Punch			
	Pin	Punch/TT 90 Punch/C	RO Φ35
	Pin	Punch/TT 90 Punch/C/Blanking	RE 5*50-0.2
	Pin	Punch/TT 90 Punch/C	RE 5*50/Rooftop
	Pin	Punch/TT 90 Punch/C (45)	RE 5*40
	Pin	Punch/TT 90 Punch/C/TiCN	RE 5*50
	Pin	Punch/TT 90 Punch/C/DF	OB Φ5*50
3# Punch/Thick Turret 85 ABS Punch			
	1 Slot	Punch/TT 85 ABS Punch/C	RO Φ35
	1 Slot	Punch/TT 85 ABS Punch/C/Blanking	RE 5*50-0.2
	1 Slot	Punch/TT 85 ABS Punch/C	RE 5*50/Rooftop
	1 Slot	Punch/TT 85 ABS Punch/C (45)	RE 5*40
	1 Slot	Punch/TT 85 ABS Punch/C/TiCN	RE 5*50
	1 Slot	Punch/TT 85 ABS Punch/C/TiCN	SQ 30*30
	1 Slot	Punch/TT 85 ABS Punch/C/DF	OB Φ5*50
	2 Slots	Punch/TT 85 ABS Punch/C/(0,180)	Class A FT/A*B
	2 Slots	Punch/TT 85 ABS Punch/C/TiCN/(0,180)	Class C FT/A*B
4# Punch/Thick Turret 85 Slitting Punch/19 Type			
	1 Slot	Punch/TT 85 Slitting Punch/19 T/C	RE 5*50
	1 Slot	Punch/TT 85 Slitting Punch/19 T/C	OB Φ5*50
	1 Slot	Punch/TT 85 Slitting Punch/19 T/C/KPM	RE 5*50
	1 Slot	Punch/TT 85 Slitting Punch/19 T/C/KPM	OB Φ5*50
	1 Slot	Punch/TT 85 Slitting Punch/19 T/C/TiCN	RE 5*50
	1 Slot	Punch/TT 85 Slitting Punch/19 T/C/TiCN	OB Φ5*50
	1 Slot	Punch/TT 85 Slitting Punch/19 T/C/DF	RE 5*50
	1 Slot	Punch/TT 85 Slitting Punch/19 T/C/DF	OB Φ5*50
5# Punch/Thick Turret Cluster Slitting Punch			
		Punch/TT 85 Cluster Slitting Punch/C	
		Punch/TT 85 Cluster Slitting Punch/C	
		Punch/TT 85 ABS Cluster Slitting Punch/C	
		Punch/TT 85 ABS Cluster Punch/C	
		Punch/TT 90 Cluster Slitting Punch/C	
		Punch/TT 90 Cluster Punch/C	

C STN (Size Range:ΦD:31.71 ~50.8mm)

C STN Stripper	Description	Size(e.g.)
1# Stripper/Thick Turret 85 Stripper 	Stripper/Thick Turret 85 Stripper/C	RO Φ35
	Stripper/Thick Turret 85 Stripper/C/Blanking	RE 5*50-0.2
	Stripper/Thick Turret 85 Stripper/C	OB Φ5*50
	Stripper/Thick Turret 85 Stripper/C	SQ 30*30
	Stripper/Thick Turret 85 Stripper/C	HX S=33
	Stripper/Thick Turret 85 Stripper/C	Class A/A*B
	Stripper/Thick Turret 85 Stripper/C	Class B B2/ØD*A
	Stripper/Thick Turret 85 Stripper/C	Class C C1/Ød*A
2# Stripper/Thick Turret 85 ABS Stripper 	Stripper/Thick Turret 85 ABS Stripper/C	RO Φ35
	Stripper/Thick Turret 85 ABS Stripper/C/Blanking	RE 5*50-0.2
	Stripper/Thick Turret 85 ABS Stripper/C	OB Φ5*50
	Stripper/Thick Turret 85 ABS Stripper/C	SQ 30*30
	Stripper/Thick Turret 85 ABS Stripper/C	HX S=33
	Stripper/Thick Turret 85 ABS Stripper/C	Class A A8/A*B
	Stripper/Thick Turret 85 ABS Stripper/C	Class B B4/ØD*A
	Stripper/Thick Turret 85 ABS Stripper/C	Class C C5/A*B
3# Stripper/Thick Turret 85 Fully Guided Stripper 	Stripper/TT 85 Fully Guided Stripper/C	RO Φ35
	Stripper/TT 85 Fully Guided Stripper/C	RE 5*50
	Stripper/TT 85 Fully Guided Stripper/C	OB Φ5*50
	Stripper/TT 85 Fully Guided Stripper/C	SQ 30*30
	Stripper/TT 85 Fully Guided Stripper/C	HX S=33
	Stripper/TT 85 Fully Guided Stripper/C	Class A A11/A*B
	Stripper/TT 85 Fully Guided Stripper/C	Class B B6/ØD*A
	Stripper/TT 85 Fully Guided Stripper/C	Class C C3/Ød*A
4# Stripper/Thick Turret 90Stripper 	Stripper/Thick Turret 90 Stripper/C	RO Φ35
	Stripper/Thick Turret 90 Stripper/C/Blanking	RE 5*50-0.2
	Stripper/Thick Turret 90 Stripper/C	OB Φ5*50
	Stripper/Thick Turret 90 Stripper/C	SQ 30*30
	Stripper/Thick Turret 90 Stripper/C	HX S=33
	Stripper/Thick Turret 90 Stripper/C	Class A A12/A*B
	Stripper/Thick Turret 90 Stripper/C	Class B B14/A*B
	Stripper/Thick Turret 90 Stripper/C	Class C C7/A*B
5# Stripper/Thick Turret 90 ABS Stripper 	Stripper/Thick Turret 90 ABS Stripper/C	RO Φ35
	Stripper/Thick Turret 90 ABS Stripper/C/Blanking	RE 5*50-0.2
	Stripper/Thick Turret 90 ABS Stripper/C	OB Φ5*50
	Stripper/Thick Turret 90 ABS Stripper/C	SQ 30*30
	Stripper/Thick Turret 90 ABS Stripper/C	HX S=33
	Stripper/Thick Turret 90 ABS Stripper/C	Class A A6/A*B
	Stripper/Thick Turret 90 ABS Stripper/C	Class B B17/A*B
	Stripper/Thick Turret 90 ABS Stripper/C	Class C FT/A*B
6# Stripper/Thick Turret Cluster Stripper 	Stripper/Thick Turret 85 Cluster Stripper/C	
	Stripper/Thick Turret 85 ABS Cluster Stripper/C	
	Stripper/Thick Turret 85 Fully Guided Stripper/C	
	Stripper/Thick Turret 90 Fully Guided Stripper/C	
	Stripper/Thick Turret 90 ABS Cluster Stripper/C	
	Stripper/Thick Turret KU Cluster Stripper/C	

THICK TURRET
C STN

C STN (Size Range:ΦD:31.71~50.8mm)

THICK TURRET
C STN

C STN Die	Slot	Description	Size (e.g.)
1# Die/Thick Turret Die			
	1 Slot	Die/Thick Turret Die/C	RO Φ40+0.15
	2 Slots	Die/Thick Turret Die/C/(45)	OB Φ8*49.27+0.15
	2 Slots	Die/Thick Turret Die/C	OB Φ14*40+1.2
	2 Slots	Die/Thick Turret Die/C/M2	RE 5*50+0.5
	2 Slots	Die/Thick Turret Die/C/(0,135)	SQ 25*25+0.4
	3 Slots	Die/Thick Turret Die/C/(0,45,90)	OB Φ5*60+0.25
	4 Slots	Die/Thick Turret Die/C/(0,90,180,270)	Class A A12/A*B+1.2
4 Slots	Die/Thick Turret Die/C/(0,90,180,270)	Class B 19/A*B+0.25	
4 Slots	Die/Thick Turret Die/C/(0,90,180,270)	Class C FT/A*B+0.4	
2# Die/Thick Turret Die/slughugger			
	1 Slot	Die/Thick Turret Die/C	RO Φ45+0.33/slughugger-1
	1 Slot	Die/Thick Turret Die/C	RO Φ50+0.2/slughugger-1
	2 Slots	Die/Thick Turret Die/C	OB Φ10*50+0.2/slughugger-1
	2 Slots	Die/Thick Turret Die/C/M2	OB Φ13*45+0.33/slughugger
	2 Slots	Die/Thick Turret Die/C	RE 5*50+0.5/slughugger
	3 Slots	Die/Thick Turret Die/C/(0,45,90)	OB Φ5*60+0.25/slughugger
4 Slots	Die/Thick Turret Die/C/(0,90,180,270)	Class BFT/A*B+1.2/slughugger	
3# Die/Thick Turret Vacuum Die			
	1 Slot	Die/Thick Turret 真空Die/C	RO Φ32+0.2
	2 Slots	Die/Thick Turret 真空Die/C	RE 5*50+0.5
	2 Slots	Die/Thick Turret 真空Die/C/M2	RE 5*50+0.5
	2 Slots	Die/Thick Turret 真空Die/C/(0,90)	SQ 28*28+0.2
	2 Slots	Die/Thick Turret 真空Die/C/(0,135)	SQ 35*35+0.3
	3 Slots	Die/Thick Turret 真空Die/C/(0,45,90)	OB Φ5*60+0.25
4 Slots	Die/Thick Turret 真空Die/C/(0,90,180,270)	Class C FT/A*B+1.2	
4# Die/Thick Turret Heavy Duty Die			
	1 Slot	Die/Thick Turret Heavy DutyDie/C	RO Φ32+0.2
	2 Slots	Die/Thick Turret Heavy DutyDie/C	RE 5*50+0.5
	2 Slots	Die/Thick Turret Heavy DutyDie/C	RE 5*50+0.2
	2 Slots	Die/Thick Turret Heavy DutyDie/C/(0,90)	SQ 20*20+1.0
	2 Slots	Die/Thick Turret Heavy DutyDie/C/(0,135)	SQ 30*30+0.2
	3 Slots	Die/Thick Turret Heavy DutyDie/C/(0,45,90)	OB Φ5*60+0.25
4 Slots	Die/Thick Turret Heavy DutyDie/C/(0,90,180,270)	四段圆弧A16/A*B+1.2	
5# Die/Thick Turret Die/Blanking			
	1 Slot	Die/Thick Turret Die/C/Blanking	RO Φ32.6
	1 Slot	Die/Thick Turret Die/C/Blanking	RO Φ40
	2 Slots	Die/Thick Turret Die/C/Blanking	RE 10*20*R5
	2 Slots	Die/Thick Turret Die/C/Blanking	SQ 25*25*R3
2 Slots	Die/Thick Turret Die/C/Blanking	OB Φ10*50	
6# Die/Thick Turret Cluster Die			
	2 Slots	Die/Thick Turret 多孔Die/C	
	2 Slots	Die/Thick Turret 多孔Die/C/M2	
	2 Slots	Die/Thick Turret Heavy Duty多孔Die/C	
	2 Slots	Die/Thick Turret 真空多孔Die/C	
7# Die/Thick Turret Special Die			
	1 Slot	Die/Thick Turret Blank Die/C	
	1 Slot	Die/Thick Turret Roller Ball Die/C	
	1 Slot	Die/Thick Turret Brush Die/C	

C STN (Size Range: Φ D:31.71 ~ 50.80mm)

C STN Guide

1# Guide/Thick Turret 85 Guide/C/(0,90)



2# Guide/Thick Turret 90 Guide/C/(0,90,225)



3# Guide/TT 85 Fully Guided Guide/C/(0,90)



C STN Punch Head Ass'y

1# PHA/TT T85 PHA/C



2# PHA/TT T85 ABS PHA/C



3# PHA/TT T90 PHA/C



4# PHA/TT HL 85 LD PHA/C



C STN Guide Ass'y

1# Guide Ass'y/TT E85 Guide Ass'y/C



2# Guide Ass'y/TT T85 Guide Ass'y/C



3# Guide Ass'y/TT T85 ABS Guide Ass'y/C



4# Guide Ass'y/TT T90 Guide Ass'y/C



5# Guide Ass'y/TT HL 85 LD Guide Ass'y/C



6# GA/TT T85 Fully Guided Guide Ass'y/C





THICK TURRET
C STN

D STN (Size Range:ΦD:50.81~88.9mm)

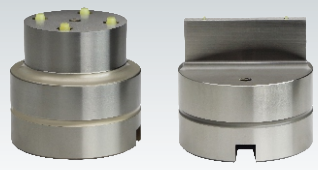
T85 D STN	Slot	Description	Size (e.g.)
1# Punch Ass'y/Thick Turret T85 Punch Ass'y			
	3 Slots	PA/TT T85 PA/D	RE 5*80
	3 Slots	PA/TT T85 PA/D	OB Φ5*80/Rooftop
	3 Slots	PA/TT T85 PA/D	RO Φ60
	3 Slots	PA/TT T85 PA/D	SQ 50*50/Rooftop
	3 Slots	PA/TT T85 PA/D	HX S=50
	3 Slots	PA/TT T85 PA/D	Class A A3/A*B
	3 Slots	PA/TT T85 PA/D	RO 4 SlotsB5/ØD*A
	3 Slots	PA/TT T85 PA/D/TiCN	Class C C3/Ød*A
	3 Slots	PA/TT T85 PA/D/TiCN	SQ 46*46
	3 Slots	PA/TT T85 PA/D/TiCN	RE 5*80
	3 Slots	PA/TT T85 PA/D/TiCN	OB Φ5*80
	3 Slots	PA/TT T85 PA/16 Type/D	RE 5*80
	3 Slots	PA/TT T85 PA/16 Type/D	RE 5*80/Rooftop
	3 Slots	PA/TT T85 PA/16 Type/D/KPM	RE 5*80
3 Slots	PA/TT T85 PA/16 Type/D/TiCN	RE 5*80	
3 Slots	PA/TT T85 PA/D/Blanking	RE 5*80-0.2	

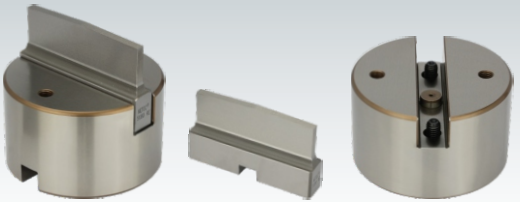
1.1# Punch/Thick Turret 85 Punch			
	1 Slot	Punch/TT 85 Punch/D	RO Φ60
	1 Slot	Punch/TT 85 Punch/D	RE 5*80
	1 Slot	Punch/TT 85 Punch/D	RE 5*80/Rooftop
	1 Slot	Punch/TT 85 Punch/D/(45)	RE 5*75
	1 Slot	Punch/TT 85 Punch/D/TiCN	RE 5*80
	1 Slot	Punch/TT 85 Punch/D/TiCN	SQ 52*52
	1 Slot	Punch/TT 85 Punch/D/DF	OB Φ5*80/Rooftop
	2 Slots	Punch/TT 85 Punch/D/(0,180)	Class BFT/A*B
	2 Slots	Punch/TT 85 Punch/D/TiCN/(0,180)	Class C FT/A*B
	1 Slot	Punch/TT 85 Punch/D/Blanking	RE 5*80-0.2

1.2# Punch/Thick Turret 85 Slitting Punch/16 Type			
	1 Slot	Punch/TT 85 Slitting Punch/16T/D	RE 5*80
	1 Slot	Punch/TT 85 Slitting Punch/16T/D	RE 5*80/Rooftop
	1 Slot	Punch/TT 85 Slitting Punch/16T/D/KPM	RE 5*80
	1 Slot	Punch/TT 85 Slitting Punch/16T/D/KPM	OB Φ5*80/Rooftop
	1 Slot	Punch/TT 85 Slitting Punch/16T/D/TiCN	RE 5*80
	1 Slot	Punch/TT 85 Slitting Punch/16T/D/TiCN	OB Φ5*80
	1 Slot	Punch/TT 85 Slitting Punch/16T/D/DF	RE 5*80
	1 Slot	Punch/TT 85 Slitting Punch/16T/D/DF	OB Φ5*80

1.3# Stripper/Thick Turret 85 Stripper			
	Stripper/Thick Turret 85 Stripper/D		RO Φ60
	Stripper/Thick Turret 85 Stripper/D		RE 5*80
	Stripper/Thick Turret 85 Stripper/D		OB Φ5*80
	Stripper/Thick Turret 85 Stripper/D		SQ 50*50
	Stripper/Thick Turret 85 Stripper/D		HX S=50
	Stripper/Thick Turret 85 Stripper/D		Class A A9/A*B
	Stripper/Thick Turret 85 Stripper/D		Class B B20/A*B
	Stripper/Thick Turret 85 Stripper/D		Class C FT/A*B
	Stripper/Thick Turret 85 Stripper/D/Blanking		RE 5*80-0.2



1.4# Guide Ass'y/TT T85 Guide Ass'y/D





1.5# Guide/TT 90 Guide/D/(0,90,225)

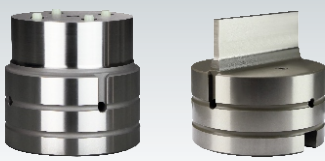
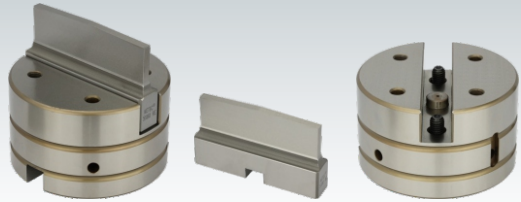

1.6# PHA/TT T85 PHA/D

D STN (Size Range:ΦD:50.81 ~ 88.9mm)

T85 ABS D STN	Slot	Description	Size(e.g.)
2# Punch Ass'y/Thick Turret T85 ABS Punch Ass'y			
	3 Slots	PA/TT T85 ABS PA/D	RE 5*80
	3 Slots	PA/TT T85 ABS PA/D	OB Φ5*80/Rooftop
	3 Slots	PA/TT T85 ABS PA/D	RO Φ60
	3 Slots	PA/TT T85 ABS PA/D	SQ 50*50/Rooftop
	3 Slots	PA/TT T85 ABS PA/D	HX S=50
	3 Slots	PA/TT T85 ABS PA/D	Class A /A*60°
	3 Slots	PA/TT T85 ABS PA/D	Class B B5/ØD*A
	3 Slots	PA/TT T85 ABS PA/D/TiCN	Class C C4/ØD*A
	3 Slots	PA/TT T85 ABS PA/D/TiCN	SQ 46*46
	3 Slots	PA/TT T85 ABS PA/D/TiCN	RE 5*80
	3 Slots	PA/TT T85 ABS PA/D/TiCN	OB Φ5*80
	3 Slots	PA/TT T85 ABS PA/16 Type/D	RE 5*80
	3 Slots	PA/TT T85 ABS PA/16 Type/D	RE 5*80/Rooftop
	3 Slots	PA/TT T85 ABS PA/16 Type/D/KPM	RE 5*80
	3 Slots	PA/TT T85 ABS PA/16 Type/D/TiCN	RE 5*80
3 Slots	PA/TT T85 ABS PA/16 Type/D/Blanking	RE 5*80-0.2	
2.1# Punch/Thick Turret 85 ABS Punch			
	1 Slot	Punch/TT 85 ABS Punch/D	RO Φ60
	1 Slot	Punch/TT 85 ABS Punch/D	RE 5*80
	1 Slot	Punch/TT 85 ABS Punch/D	RE 5*80/Rooftop
	1 Slot	Punch/TT 85 ABS Punch/D/(45)	RE 5*75
	1 Slot	Punch/TT 85 ABS Punch/D/TiCN	RE 5*80
	1 Slot	Punch/TT 85 ABS Punch/D/TiCN	SQ 52*52
	1 Slot	Punch/TT 85 ABS Punch/D/DF	OB Φ5*80/Rooftop
	2 Slots	Punch/TT 85 ABS Punch/D/(0, 180)	Class C C7/A*B
	2 Slots	Punch/TT 85 ABS Punch/D/TiCN/(0, 180)	Class C FT/A*B
	1 Slot	Punch/TT 85 ABS Punch/D/Blanking	RE 5*80-0.2
	2.2# Punch/Thick Turret 85 ABS Slitting Punch/16 Type		
	1 Slot	Punch/TT 85 ABS Slitting Punch/16T/D	RE 5*80
	1 Slot	Punch/TT 85 ABS Slitting Punch/16T/D	RE 5*80/Rooftop
	1 Slot	Punch/TT 85 ABS S-Punch/16T/D/KPM	RE 5*80
	1 Slot	Punch/TT 85 ABS S-Punch/16T/D/KPM	OB Φ5*80/Rooftop
	1 Slot	Punch/TT 85 ABS S-Punch/16T/D/TiCN	RE 5*80
	1 Slot	Punch/TT 85 ABS S-Punch/16T/D/TiCN	OB Φ5*80
	1 Slot	Punch/TT 85 ABS S-Punch/16T/D/DF	RE 5*80
	1 Slot	Punch/TT 85 ABS S-Punch/16T/D/DF	OB Φ5*80
2.3# Stripper/Thick Turret 85 ABS Stripper			
	Stripper/Thick Turret 85 ABS Stripper/D	RO Φ60	
	Stripper/Thick Turret 85 ABS Stripper/D	RE 5*80	
	Stripper/Thick Turret 85 ABS Stripper/D	OB Φ5*80	
	Stripper/Thick Turret 85 ABS Stripper/D	SQ 50*50	
	Stripper/Thick Turret 85 ABS Stripper/D	HX S=50	
	Stripper/Thick Turret 85 ABS Stripper/D	Class A A5/A*B	
	Stripper/Thick Turret 85 ABS Stripper/D	Class B B9/A*B*R	
	Stripper/Thick Turret 85 ABS Stripper/D	Class C C11/A*B	
	Stripper/Thick Turret 85 ABS Stripper/D/Blanking	RE 5*80-0.2	

THICK TURRET D STN

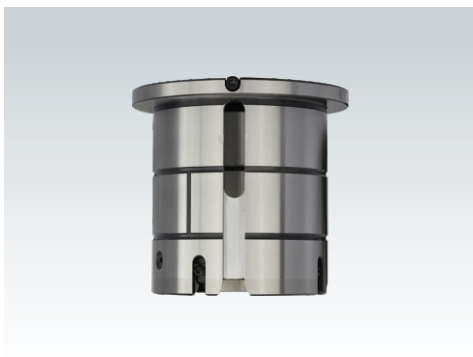

2.4# Guide Ass'y/TT T85 ABS Guide Ass'y/D

2.5# Guide/Thick Turret 90Guide/D/(0,90,225)

2.6# PHA/TT T85 ABS PHA/D

D STN (Size Range:ΦD:50.81~88.9mm)

T85 ABS D STN	Slot	Description	Size(e.g.)
3# Punch Ass'y/Thick Turret T85 Fully Guided Punch Ass'y			
	2 Slots	PA/TT T85 Fully Guided PA/D	RE 5*80
	2 Slots	PA/TT T85 Fully Guided PA/D	OB Φ5*80/Rooftop
	2 Slots	PA/TT T85 Fully Guided PA/D	RE 5*80
	2 Slots	PA/TT T85 Fully Guided PA/D	RE 5*80/Rooftop
	2 Slots	PA/TT T85 Fully Guided PA/D	OB Φ5*80
	2 Slots	PA/TT T85 Fully Guided PA/D	RE 5*80
	2 Slots	PA/TT T85 Fully Guided PA/D	RE 5*80
	2 Slots	PA/TT T85 Fully Guided PA/D/TiCN	RE 5*80
	2 Slots	PA/TT T85 Fully Guided PA/D/TiCN	OB Φ5*80
	2 Slots	PA/TT T85 Fully Guided PA/D/TiCN	RE 5*80
	2 Slots	PA/TT T85 Fully Guided PA/D/TiCN	OB Φ5*80
	2 Slots	PA/TT T85 Fully Guided PA/16 T/D	RE 5*80
	2 Slots	PA/TT T85 Fully Guided PA/16 T/D	RE 5*80/Rooftop
	2 Slots	PA/TT T85 Fully Guided PA/16 T/D/KPM	Class B B11/A*B
2 Slots	PA/TT T85 Fully Guided PA/16 T/D/TiCN	Class B B12/A*B	
3.1# Punch/Thick Turret 85 Punch			
	1 Slot	Punch/TT 85 Punch/D	OB Φ5*80
	1 Slot	Punch/TT 85 Punch/D	RE 5*80
	1 Slot	Punch/TT 85 Punch/D	RE 5*80/Rooftop
	1 Slot	Punch/TT 85 Punch/D/(45)	OB Φ5*80
	1 Slot	Punch/TT 85 Punch/D/TiCN	RE 5*80
	1 Slot	Punch/TT 85 Punch/D/TiCN	RE 5*75
	1 Slot	Punch/TT 85 Punch/D/DF	OB Φ5*80/Rooftop
	2 Slots	Punch/TT 85 Punch/D/(0,180)	Class B B11/A*B
	2 Slots	Punch/TT 85 Punch/D/TiCN/(0,180)	Class B B12/A*B
3.2# Stripper/Thick Turret 85 Fully Guided Stripper			
	Stripper/TT 85 Fully Guided Stripper/D	OB Φ5*80	
	Stripper/TT 85 Fully Guided Stripper/D	RE 5*80	
	Stripper/TT 85 Fully Guided Stripper/D	OB Φ5*80	
	Stripper/TT 85 Fully Guided Stripper/D	RE 5*80	
	Stripper/TT 85 Fully Guided Stripper/D	RE 5*80	
	Stripper/TT 85 Fully Guided Stripper/D	RE 5*80	
	Stripper/TT 85 Fully Guided Stripper/D	Class B B11/A*B	
	Stripper/TT 85 Fully Guided Stripper/D	Class B B12/A*B	

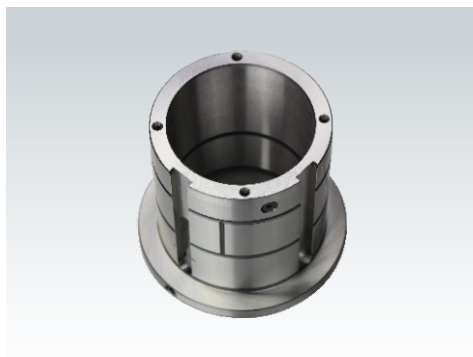

3.3# GA/Thick Turret T85 Fully Guided GA/D 3.4# Guide/TT 85 Fully Guided Guide/D/(0,90) 3.5# PHA/Thick Turret T85 PHA/D

D STN (Size Range:ΦD:50.81 ~ 88.9mm)

T85 Light Duty D STN	Slot	Description	Size(e.g.)
4# Punch Ass'y/Thick Turret HL 85 Light Duty Punch Ass'y			
 <div style="display: flex; flex-direction: column; align-items: center;"> <div style="display: flex; align-items: center; margin-bottom: 10px;">  <p>Light Duty (Blue)</p> </div> <div style="display: flex; align-items: center; margin-bottom: 10px;">  <p>Middle Duty (Red)</p> </div> <div style="display: flex; align-items: center;">  <p>Heavy Duty (Green)</p> </div> </div>	2 Slots	PA/TT HL 85 Light Duty PA/D	RE 5*80
	2 Slots	PA/TT HL 85 Light Duty PA/D	OB Φ5*80/Rooftop
	2 Slots	PA/TT HL 85 Light Duty PA/D	RO Φ60
	2 Slots	PA/TT HL 85 Light Duty PA/D	SQ 50*50/Rooftop
	2 Slots	PA/TT HL 85 Light Duty PA/D	HX S=50
	2 Slots	PA/TT HL 85 Light Duty PA/D	Class A A3/A*B
	2 Slots	PA/TT HL 85 Light Duty PA/D	Class B B14/A*B
	2 Slots	PA/TT HL 85 Light Duty PA/D/TiCN	Class C FT/A*B
	2 Slots	PA/TT HL 85 Light Duty PA/D/TiCN	SQ 46*46
	2 Slots	PA/TT HL 85 Light Duty PA/D/TiCN	RE 5*80
	2 Slots	PA/TT HL 85 Light Duty PA/16 T/D	OB Φ5*80
	2 Slots	PA/TT HL 85 Light Duty PA/16 T/D	RE 5*80
	2 Slots	PA/TT HL 85 Light Duty PA/16 T/D/KPM	RE 5*80/Rooftop
	2 Slots	PA/TT HL 85 Light Duty PA/16 T/D/TiCN	RE 5*80
4.1# Punch/Thick Turret 85 Punch			
	1 Slot	Punch/TT 85 Punch/D	RO Φ60
	1 Slot	Punch/TT 85 Punch/D	RE 5*80
	1 Slot	Punch/TT 85 Punch/D	RE 5*80/Rooftop
	1 Slot	Punch/TT 85 Punch/D/(45)	RE 5*75
	1 Slot	Punch/TT 85 Punch/D/TiCN	RE 5*80
	1 Slot	Punch/TT 85 Punch/D/TiCN	SQ 52*52
	1 Slot	Punch/TT 85 Punch/D/DF	OB Φ5*80/Rooftop
	2 Slots	Punch/TT 85 Punch/D/(0,180)	Class C C1/Ød*A
	2 Slots	Punch/TT 85 Punch/D/TiCN/(0,180)	Class C FT/A*B
	4.2# Punch/Thick Turret 85 Slitting Punch/16T		
	1 Slot	Punch/TT 85 Slitting Punch/16 T/D	RE 5*80
	1 Slot	Punch/TT 85 Slitting Punch/16 T/D	RE 5*80/Rooftop
	1 Slot	Punch/TT 85 Slitting Punch/16 T/D/KPM	RE 5*80
	1 Slot	Punch/TT 85 Slitting Punch/16 T/D/KPM	OB Φ5*80/Rooftop
	1 Slot	Punch/TT 85 Slitting Punch/16 T/D/TiCN	RE 5*80
	1 Slot	Punch/TT 85 Slitting Punch/16 T/D/TiCN	OB Φ5*80
	1 Slot	Punch/TT 85 Slitting Punch/16 T/D/DF	RE 5*80
	1 Slot	Punch/TT 85 Slitting Punch/16 T/D/DF	OB Φ5*80
	4.3# Stripper/Thick Turret 85 Stripper		
	Stripper/Thick Turret 85Stripper/D		RO Φ60
	Stripper/Thick Turret 85Stripper/D		RE 5*80
	Stripper/Thick Turret 85Stripper/D		OB Φ5*80
	Stripper/Thick Turret 85Stripper/D		SQ 50*50
	Stripper/Thick Turret 85Stripper/D		HX S=50
	Stripper/Thick Turret 85Stripper/D		Class A A10/A*B
	Stripper/Thick Turret 85Stripper/D		Class B B22/A*B
	Stripper/Thick Turret 85Stripper/D		Class C FT/A*B
	4.4# GA/TT HL 85 Light Duty Guide Ass'y/D		
4.5# Guide/TT 90 Guide/D/(0,90,225)			
4.6# PHA/TT HL 85 Light Duty PHA/D			

THICK TURRET D STN

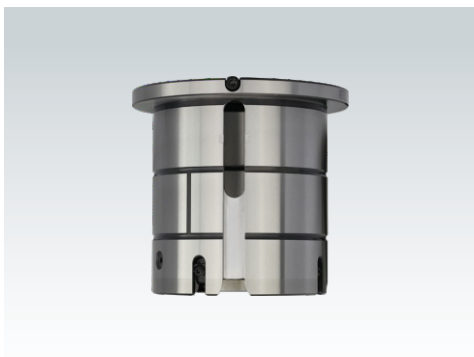

4.4# GA/TT HL 85 Light Duty Guide Ass'y/D

4.5# Guide/TT 90 Guide/D/(0,90,225)

4.6# PHA/TT HL 85 Light Duty PHA/D

D STN (Size Range:ΦD:50.81~88.9mm)

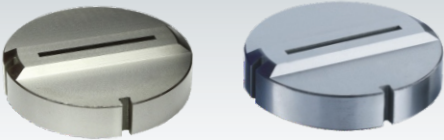
HR Close To Clamp D STN	Slot	Description	Size (e.g.)
5# Punch Ass'y/Thick Turret HR Close To Clamp Punch Ass'y			
	2 Slots	PA/Thick Turret HR PA/D	RE 5*80
	2 Slots	PA/Thick Turret HR PA/D	OB Φ5*80/Rooftop
	2 Slots	PA/Thick Turret HR PA/D/TiCN	RE 5*80
5.1# Punch/Thick Turret HR Close To Clamp Punch			
	1 Slot	Punch/TT HR CTC Punch/D	RE 5*80
	1 Slot	Punch/TT HR CTC Punch/D	RE 5*80/Rooftop
	1 Slot	Punch/TT HR CTC Punch/D/TiCN	OB Φ6*80
5.2# Stripper/Thick Turret HR Close To Clamp Stripper			
	Stripper/Thick Turret HR CTC Stripper/D		RE 5*80
	Stripper/Thick Turret HR CTC Stripper/D		OB Φ5*80
5.3# Die/Thick Turret Close To Clamp Die			
	2 Slots	Die/TT Single Side Die/D	RE 5*80+0.15
	2 Slots	Die/TT Single Side Die/D	OB Φ5*60+0.25
	2 Slots	Die/TT Single Side Die/D	RE 5*80+0.2
	2 Slots	Die/TT Single Side Die/D/LD	OB Φ5*60+0.25
	2 Slots	Die/TT Double-Side Die/D	RE 5*75+0.4
	2 Slots	Die/TT Double-Side Die/D	OB Φ5*60+0.25
	2 Slots	Die/TT Double-Side Vaccum Die/D	RE 5*80+0.4
	2 Slots	Die/TT Double-Side Vaccum Die/D	OB Φ5*60+0.25
2 Slots	Die/TT Double-Side Vaccum Die/D/M2	RE 5*70+0.35	



5.4# GA/Thick Turret HR CTC Guide Ass'y/D

5.5# Guide/Thick Turret HR CTC Guide/D/(0,90)

D STN (Size Range:ΦD:50.81 ~ 88.9mm)

HR Light Duty D STN	Slot	Description	Size(e.g.)	
6# Punch Ass'y/Thick Turret HR Light Duty Punch Ass'y				
 <div style="display: flex; flex-direction: column; align-items: center;"> <div style="display: flex; align-items: center;">  <p>Light Duty (Blue)</p> </div> <div style="display: flex; align-items: center;">  <p>Middle Duty (Red)</p> </div> <div style="display: flex; align-items: center;">  <p>Heavy Duty (Green)</p> </div> </div>	2 Slots	PA/Thick Turret HR LD CTC PA/D	RE 5*80	
	2 Slots	PA/Thick Turret HR LD CTC PA/D	OB Φ5*80/Rooftop	
	2 Slots	PA/TT HR LD CTC PA/D/TiCN	RE 5*80	
	2 Slots	PA/TT HR LD CTC PA/D/TiCN	OB Φ5*80	
6.1# Punch/Thick Turret HR Close To Clamp Punch				
	1 Slot	Punch/TT HR CTC Punch/D	RE 5*80	
	1 Slot	Punch/TT HR CTC Punch/D	RE 5*80/Rooftop	
	1 Slot	Punch/TT HR CTC Punch/D/TiCN	RE 5*80	
	1 Slot	Punch/TT HR CTC Punch/D/DF	OB Φ6*80/Rooftop	
6.2# Stripper/Thick Turret HR Close To Clamp Stripper				
		Stripper/Thick Turret HR CTC Stripper/D	RE 5*80	
		Stripper/Thick Turret HR CTC Stripper/D	OB Φ5*80	

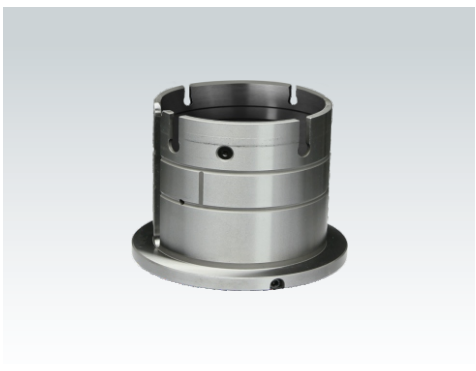

THICK TURRET D STN



6.3# GA/Thick Turret HR CTC Guide Ass'y/D

6.4# Guide/Thick Turret HR CTC Guide/D/(0,90)

D STN (Size Range:ΦD:50.81~88.9mm)

T90 D STN	Slot	Description	Size(e.g.)
7# Punch Ass'y/Thick Turret T90 Punch Ass'y			
	3 Slots	PHA/Thick Turret T90PHA/D	RE 5*80
	3 Slots	PHA/Thick Turret T90PHA/D	OB Φ5*80/Rooftop
	3 Slots	PHA/Thick Turret T90PHA/D	RO Φ60
	3 Slots	PHA/Thick Turret T90PHA/D	SQ 50*50/Rooftop
	3 Slots	PHA/Thick Turret T90PHA/D	HX S=50
	3 Slots	PHA/Thick Turret T90PHA/D	Class A/A*B*R
	3 Slots	PHA/Thick Turret T90PHA/D	Class B/B21/A*B
	3 Slots	PHA/Thick Turret T90PHA/D/TiCN	Class C/C6/A*B
	3 Slots	PHA/Thick Turret T90PHA/D/TiCN	SQ 46*46
	3 Slots	PHA/Thick Turret T90PHA/D/TiCN	RE 5*80
	3 Slots	PHA/Thick Turret T90PHA/D/TiCN	OB Φ5*80
	3 Slots	PHA/Thick Turret T90PHA/D/Blanking	RE 5*80-0.2
	7.1# Punch/Thick Turret 90 Punch		
	Pin	Punch/TT 90 Punch/D	RO Φ60
	Pin	Punch/TT 90 Punch/D	RE 5*80
	Pin	Punch/TT 90 Punch/D	RE 5*80/Rooftop
	Pin	Punch/TT 90 Punch/D/(45)	RE 5*75
	Pin	Punch/TT 90 Punch/D/TiCN	RE 5*80
	Pin	Punch/TT 90 Punch/D/TiCN	SQ 52*52
	Pin	Punch/TT 90 Punch/D/DF	OB Φ5*80/Rooftop
	Pin	Punch/TT 90 Punch/D/(0,180)	Class B FT/A*B
	Pin	Punch/TT 90 Punch/D/TiCN/(0,180)	Class C FT/A*B
	Pin	Punch/TT 90 Punch/D/Blanking	RE 5*80-0.2
7.2# Stripper/Thick Turret 90 Stripper			
	Stripper/Thick Turret 90 Stripper/D		RO Φ60
	Stripper/Thick Turret 90 Stripper/D		RE 5*80
	Stripper/Thick Turret 90 Stripper/D		OB Φ5*80
	Stripper/Thick Turret 90 Stripper/D		SQ 50*50
	Stripper/Thick Turret 90 Stripper/D		HX S=50
	Stripper/Thick Turret 90 Stripper/D		Class A A15/A*B
	Stripper/Thick Turret 90 Stripper/D		Class B B15/A*B
	Stripper/Thick Turret 90 Stripper/D		Class C FT/A*B
	Stripper/Thick Turret 90 Stripper/D		RE 5*80-0.2
	Stripper/Thick Turret 90 Stripper/D/Blanking		



7.3# Guide Ass'y/Thick Turret T90 Guide Ass'y/D

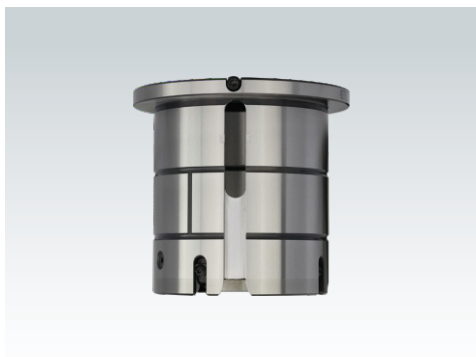

7.4# Guide/Thick Turret 90 Guide/D/(0,90,225)



7.5# PHA/Thick Turret T90 PHA/D

D STN (Size Range:ΦD:50.81 ~ 88.9mm)

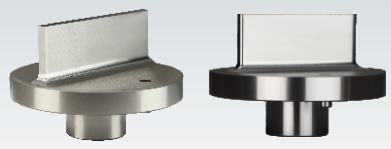
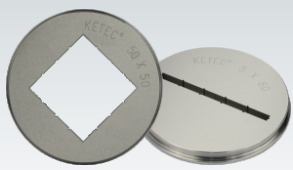
T90 ABS D STN	Slot	Description	Size(e.g.)
8# Punch Ass'y/Thick Turret T90 ABS Punch Ass'y			
	3 Slots	PA/Thick Turret T90 ABS PA/D	RE 5*80
	3 Slots	PA/Thick Turret T90 ABS PA/D	OB Φ5*80/Rooftop
	3 Slots	PA/Thick Turret T90 ABS PA/D	RO Φ60
	3 Slots	PA/Thick Turret T90 ABS PA/D	SQ 50*50/Rooftop
	3 Slots	PA/Thick Turret T90 ABS PA/D	HX S=50
	3 Slots	PA/Thick Turret T90 ABS PA/D	Class A/A*B
	3 Slots	PA/Thick Turret T90 ABS PA/D	Class B/B6/ØD*A
	3 Slots	PA/Thick Turret T90 ABS PA/D/TiCN	Class C FT/A*B
	3 Slots	PA/Thick Turret T90 ABS PA/D/TiCN	SQ 46*46
	3 Slots	PA/Thick Turret T90 ABS PA/D/TiCN	RE 5*80
3 Slots	PA/Thick Turret T90 ABS PA/D/TiCN	OB Φ5*80	
8.1# Punch/Thick Turret 90 Punch			
	Pin	Punch/TT 90 Punch/D	RO Φ60
	Pin	Punch/TT 90 Punch/D	RE 5*80
	Pin	Punch/TT 90 Punch/D	RE 5*80/Rooftop
	Pin	Punch/TT 90 Punch/D/(45)	RE 5*75
	Pin	Punch/TT 90 Punch/D/TiCN	RE 5*80
	Pin	Punch/TT 90 Punch/D/TiCN	SQ 52*52
	Pin	Punch/TT 90 Punch/D/DF	OB Φ5*80/Rooftop
	Pin	Punch/TT 90 Punch/D/(0,180)	Class C/FT/A*B
	Pin	Punch/TT 90 Punch/D/TiCN/(0,180)	Class C/C11/A*B
8.2# Stripper/Thick Turret 90 ABS Stripper			
	Stripper/Thick Turret 90ABS Stripper/D		RO Φ60
	Stripper/Thick Turret 90ABS Stripper/D		RE 5*80
	Stripper/Thick Turret 90ABS Stripper/D		OB Φ5*80
	Stripper/Thick Turret 90ABS Stripper/D		SQ 50*50
	Stripper/Thick Turret 90ABS Stripper/D		HX S=50
	Stripper/Thick Turret 90ABS Stripper/D		Class A/A6/A*B
	Stripper/Thick Turret 90ABS Stripper/D		Class B/B12/A*B
	Stripper/Thick Turret 90ABS Stripper/D		Class C/C6/A*B

THICK TURRET D STN



8.3# Guide Ass'y/TT T90ABS Guide Ass'y/D



8.4# Guide/Thick Turret 90 Guide/D/(0,90,225)



8.5# PHA/Thick Turret T90 PHA/D

D STN (Size Range:ΦD:50.81~88.9mm)

E85 D STN	Slot	Description	Size(e.g.)
9# Punch Ass'y/Thick Turret E85 Punch Ass'y			
	2 Slots	PA/Thick Turret E85 PA/D	RE 5*80
	2 Slots	PA/Thick Turret E85 PA/D	OB Φ5*80/Rooftop
	2 Slots	PA/Thick Turret E85 PA/D/Blanking	RO Φ60-0.2
	2 Slots	PA/Thick Turret E85 PA/D	SQ 50*50/Rooftop
	2 Slots	PA/Thick Turret E85 PA/D	HX S=50
	2 Slots	PA/Thick Turret E85 PA/D	Class A7/A*B
	2 Slots	PA/Thick Turret E85 PA/D	Class B12/A*B
	2 Slots	PA/Thick Turret E85 PA/D/TiCN	Class C10/A*B
	2 Slots	PA/Thick Turret E85 PA/D/TiCN	SQ 46*46
	2 Slots	PA/Thick Turret E85 PA/D/TiCN	RE 5*80
	2 Slots	PA/Thick Turret E85 PA/D/TiCN	OB Φ5*80
	2 Slots	PA/Thick Turret E85 PA/16 Type/D	RE 5*80
	2 Slots	PA/Thick Turret E85 PA/16 Type/D	RE 5*80/Rooftop
	2 Slots	PA/Thick Turret E85 PA/16 Type/D/KPM	RE 5*80
	2 Slots	PA/Thick Turret E85 PA/16 Type/D/TiCN	RE 5*80
	3 Slots	PA/Thick Turret E85 PA/D	RE 5*80
4 Slots	PA/Thick Turret E85 PA/D	RE 5*80	

9.1# Punch/Thick Turret 85 Punch			
	1 Slot	Punch/Thick Turret 85 Punch/D	RO Φ60
	1 Slot	Punch/Thick Turret 85 Punch/D	RE 5*80
	1 Slot	Punch/Thick Turret 85 Punch/D	RE 5*80/Rooftop
	1 Slot	Punch/Thick Turret 85 Punch/D/(45)	RE 5*75
	1 Slot	Punch/Thick Turret 85 Punch/D/TiCN	RE 5*80
	1 Slot	Punch/Thick Turret 85 Punch/D/TiCN	SQ 52*52
	1 Slot	Punch/Thick Turret 85 Punch/D/DF	OB Φ5*80/Rooftop
	2 Slots	Punch/Thick Turret 85 Punch/D/(0,180)	Key Hole C2/Ød*A
	2 Slots	Punch/Thick Turret 85 P/D/TiCN/(0,180)	Key Hole C3/Ød*A
	1 Slot	Punch/Thick Turret 85 P/D/Blanking	RE 5*80-0.3

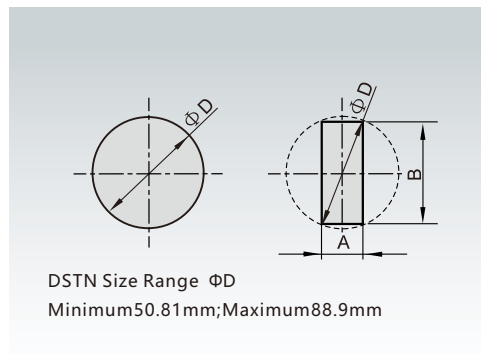

9.2# Punch/Thick Turret 85 Slitting Punch/16 Type			
	1 Slot	Punch/TT 85 SP/16 T/D	RE 5*80
	1 Slot	Punch/TT 85 SP/16 T/D	RE 5*80/Rooftop
	1 Slot	Punch/TT 85 SP/16 T/D/KPM	RE 5*80
	1 Slot	Punch/TT 85 SP/16 T/D/KPM	OB Φ5*80/Rooftop
	1 Slot	Punch/TT 85 SP/16 T/D/TiCN	RE 5*80
	1 Slot	Punch/TT 85 SP/16 T/D/TiCN	OB Φ5*80
	1 Slot	Punch/TT 85 SP/16 T/D/DF	RE 5*80
	1 Slot	Punch/TT 85 SP/16 T/D/DF	OB Φ5*80

9.3# Stripper/Thick Turret 85 Stripper			
	Stripper/Thick Turret 85 Stripper/D		RO Φ60
	Stripper/Thick Turret 85 Stripper/D		RE 5*80
	Stripper/Thick Turret 85 Stripper/D		OB Φ5*80
	Stripper/Thick Turret 85 Stripper/D		SQ 50*50
	Stripper/Thick Turret 85 Stripper/D		HX S=50
	Stripper/Thick Turret 85 Stripper/D		Class A13/A*B
	Stripper/Thick Turret 85 Stripper/D		4 Way Radius B9/A*B*R
	Stripper/Thick Turret 85 Stripper/D		Class C10/A*B
	Stripper/Thick Turret 85 Stripper/D/Blanking		RE 5*80-0.2



9.4# Guide Ass'y/Thick Turret E85 Guide Ass'y/D 9.5# Guide/Thick Turret 85 Guide/D/(0,90)

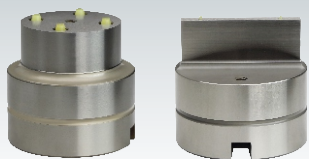
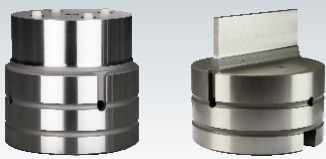
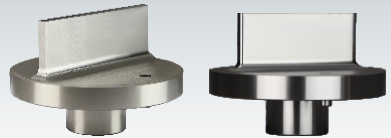
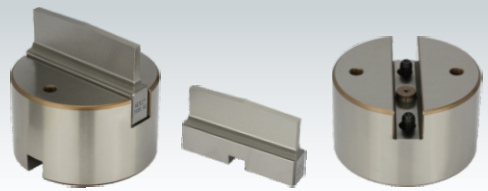
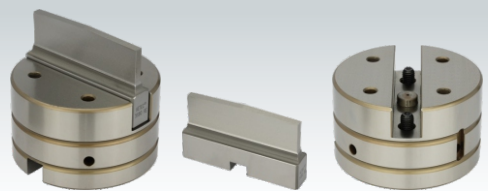
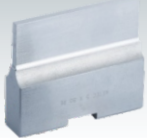





D STN (Size Range:ΦD:50.81 ~ 88.9mm)

D STN Punch	Slot	Description	Size(e.g.)	
1# Punch/Thick Turret 85 Punch				
	1 Slot	Punch/TT 85 Punch/D	RO Φ60	
	1 Slot	Punch/TT 85 Punch/D/Blanking	RE 5*80-0.2	
	1 Slot	Punch/TT 85 Punch/D	RE 5*80/Rooftop	
	1 Slot	Punch/TT 85 Punch/D/(45)	RE 5*75	
	1 Slot	Punch/TT 85 Punch/D/TiCN	RE 5*80	
	1 Slot	Punch/TT 85 Punch/D/TiCN	SQ 52*52	
	1 Slot	Punch/TT 85 Punch/D/DF	OB Φ5*80/Rooftop	
	2 Slots	Punch/TT 85 Punch/D/(0,180)	Key Hole C4/ØD*A	
	2 Slots	Punch/TT 85 Punch/D/TiCN/(0,180)	Class C FT/A*B	
	2# Punch/Thick Turret 85 ABS Punch			
	1 Slot	Punch/TT 85 ABS Punch/D	RO Φ60	
	1 Slot	Punch/TT 85 ABS Punch/D/Blanking	RE 5*80-0.2	
	1 Slot	Punch/TT 85 ABS Punch/D	RE 5*80/Rooftop	
	1 Slot	Punch/TT 85 ABS Punch/D/(45)	RE 5*75	
	1 Slot	Punch/TT 85 ABS Punch/D/TiCN	RE 5*80	
	1 Slot	Punch/TT 85 ABS Punch/D/TiCN	SQ 52*52	
	1 Slot	Punch/TT 85 ABS Punch/D/DF	OB Φ5*80/Rooftop	
	2 Slots	Punch/TT 85 ABS Punch/D/(0,180)	Class C FT/A*B	
	2 Slots	Punch/TT 85 ABS Punch/D/TiCN/(0,180)	4 Way Radius C11/A*B	
	3# Punch/Thick Turret 90 Punch			
	Pin	Punch/TT 90 Punch/D	RO Φ60	
	Pin	Punch/TT 90 Punch/D/Blanking	RE 5*80-0.3	
	Pin	Punch/TT 90 Punch/D	RE 5*80/Rooftop	
	Pin	Punch/TT 90 Punch/D/(45)	RE 5*75	
	Pin	Punch/TT 90 Punch/D/TiCN	RE 5*80	
	Pin	Punch/TT 90 Punch/D/TiCN	SQ 52*52	
	Pin	Punch/TT 90 Punch/D/DF	OB Φ5*80/Rooftop	
	Pin	Punch/TT 90 Punch/D/(0,180)	Class BFT/A*B	
	Pin	Punch/TT 90 Punch/D/TiCN/(0,180)	Class C FT/A*B	
	4# Punch/Thick Turret 85 Slitting Punch/16 Type			
	1 Slot	Punch/TT 85 SP/16 T/D	RE 5*80	
	1 Slot	Punch/TT 85 SP/16 T/D	RE 5*80/Rooftop	
	1 Slot	Punch/TT 85 SP/16 T/D/KPM	RE 5*80	
	1 Slot	Punch/TT 85 SP/16 T/D/KPM	OB Φ5*80/Rooftop	
	1 Slot	Punch/TT 85 SP/16 T/D/TiCN	RE 5*80	
	1 Slot	Punch/TT 85 SP/16 T/D/TiCN	OB Φ5*80	
	1 Slot	Punch/TT 85 SP/16 T/D/DF	RE 5*80	
	1 Slot	Punch/TT 85 SP/16 T/D/DF	OB Φ5*80	
	5# Punch/Thick Turret 85 ABS Slitting Punch/16 Type			
		1 Slot	Punch/TT 85 ABS SP/16 T/D	RE 5*80
1 Slot		Punch/TT 85 ABS SP/16 T/D	RE 5*80/Rooftop	
1 Slot		Punch/TT 85 ABS SP/16 T/D/KPM	RE 5*80	
1 Slot		Punch/TT 85 ABS SP/16 T/D/KPM	OB Φ5*80/Rooftop	
1 Slot		Punch/TT 85 ABS SP/16 T/D/TiCN	RE 5*80	
1 Slot		Punch/TT 85 ABS SP/16 T/D/TiCN	OB Φ5*80	
1 Slot		Punch/TT 85 ABS SP/16 T/D/DF	RE 5*80	
1 Slot		Punch/TT 85 ABS SP/16 T/D/DF	OB Φ5*80	
6# Punch/Thick Turret HR Close To Clamp Punch				
		1 Slot	Punch/TT HR CTC Punch/D	RE 5*80
	1 Slot	Punch/TT HR CTC Punch/D	RE 5*80/Rooftop	
	1 Slot	Punch/TT HR CTC Punch/D/TiCN	OB Φ6*80	
7# Punch/Thick Turret Cluster Slitting Punch				
		Punch/Thick Turret 85 Cluster S-Punch/D		
		Punch/Thick Turret 85 Cluster S-Punch/D		
		Punch/Thick Turret 85 ABS C- Punch/D		
		Punch/Thick Turret 85 ABS C- Punch/D		
		Punch/Thick Turret 90 Cluster S-Punch/D		
		Punch/Thick Turret 90 Cluster Punch/D		

THICK TURRET D STN

D STN (Size Range:ΦD:50.81~88.9mm)

THICK TURRET
D STN

D STN Stripper	Description	Size (e.g.)
1# Stripper/Thick Turret 85 Stripper		
	Stripper/Thick Turret 85 Stripper/D	RO Φ60
	Stripper/Thick Turret 85 Stripper/D/Blanking	RE 5*80-0.3
	Stripper/Thick Turret 85 Stripper/D	OB Φ5*80
	Stripper/Thick Turret 85 Stripper/D	SQ 50*50
	Stripper/Thick Turret 85 Stripper/D	HX S=50
	Stripper/Thick Turret 85 Stripper/D	Class A/A*B*R
	Stripper/Thick Turret 85 Stripper/D	Class B B5/ØD*A
Stripper/Thick Turret 85 Stripper/D	Class C C4/ØD*A	
2# Stripper/Thick Turret 85 ABS Stripper		
	Stripper/Thick Turret 85ABS Stripper/D	RO Φ60
	Stripper/Thick Turret 85ABS Stripper/D/Blanking	RE 5*80-0.3
	Stripper/Thick Turret 85ABS Stripper/D	OB Φ5*80
	Stripper/Thick Turret 85ABS Stripper/D	SQ 50*50
	Stripper/Thick Turret 85ABS Stripper/D	HX S=50
	Stripper/Thick Turret 85ABS Stripper/D	Class A D/A*B
	Stripper/Thick Turret 85ABS Stripper/D	Class B9/A*B*R
Stripper/Thick Turret 85ABS Stripper/D	Class C FT/A*B	
3# Stripper/Thick Turret 90 Stripper		
	Stripper/Thick Turret 90Stripper/D	RO Φ60
	Stripper/Thick Turret 90Stripper/D/Blanking	RE 5*80-0.3
	Stripper/Thick Turret 90Stripper/D	OB Φ5*80
	Stripper/Thick Turret 90Stripper/D	SQ 50*50
	Stripper/Thick Turret 90Stripper/D	HX S=50
	Stripper/Thick Turret 90Stripper/D	Class A A4/A*B
	Stripper/Thick Turret 90Stripper/D	Class B B8/A*B*R
Stripper/Thick Turret 90Stripper/D	Class C C10/A*B	
4# Stripper/Thick Turret 90 ABS Stripper		
	Stripper/Thick Turret 90ABS Stripper/D	RO Φ60
	Stripper/Thick Turret 90ABS Stripper/D/Blanking	RE 5*80-0.3
	Stripper/Thick Turret 90ABS Stripper/D	OB Φ5*80
	Stripper/Thick Turret 90ABS Stripper/D	SQ 50*50
	Stripper/Thick Turret 90ABS Stripper/D	HX S=50
	Stripper/Thick Turret 90ABS Stripper/D	Class A/A
	Stripper/Thick Turret 90ABS Stripper/D	Class B B9/A*B*R
Stripper/Thick Turret 90ABS Stripper/D	Class C FT/A*B	
5# Stripper/Thick Turret 85 Fully Guided Stripper		
	Stripper/Thick Turret 85 Fully Guided Stripper/D	RO Φ60
	Stripper/Thick Turret 85 Fully Guided Stripper/D	RE 5*80
	Stripper/Thick Turret 85 Fully Guided Stripper/D	OB Φ5*80
	Stripper/Thick Turret 85 Fully Guided Stripper/D	SQ 50*50
	Stripper/Thick Turret 85 Fully Guided Stripper/D	HX S=50
	Stripper/Thick Turret 85 Fully Guided Stripper/D	Class A A13/A*B
	Stripper/Thick Turret 85 Fully Guided Stripper/D	Class B B19/A*B
Stripper/Thick Turret 85 Fully Guided Stripper/D	Class C FT/A*B	
6# Stripper/Thick Turret HR Close To Clamp Stripper		
	Stripper/Thick Turret HR Close To Clamp Stripper/D	RE 5*80
	Stripper/Thick Turret HR Close To Clamp Stripper/D	OB Φ5*80
7# Stripper/Thick Turret Cluster Stripper		
	Stripper/Thick Turret 85 Cluster Stripper/D	
	Stripper/Thick Turret 85 ABS Cluster Stripper/D	
	Stripper/Thick Turret 85 Fully Guided Stripper/D	
	Stripper/Thick Turret 90 Cluster Stripper/D	
	Stripper/Thick Turret 90 ABS Cluster Stripper/D	
	Stripper/Thick Turret KU Cluster Stripper/D	

D STN (Size Range: Φ D:50.81 ~ 88.9mm)

D STN Die	Slot	Description	Size(e.g.)
1# Die/Thick Turret Die			
	1 Slot	Die/Thick Turret Die/D	RO Φ 52+0.15
	2 Slots	Die/Thick Turret Die/D	RE 5*80+0.4
	2 Slots	Die/Thick Turret Die/D/M2	RE 5*80+0.3
	2 Slots	Die/Thick Turret Die/D/(0,90)	SQ 45*45+0.3
	2 Slots	Die/Thick Turret Die/D/(0,135)	SQ 45*45+0.3
	4 Slots	Die/Thick Turret Die/D/(0,90,180,270)	Class B/B13/A*B+0.25
2# Die/Thick Turret Die/slughugger			
	1 Slot	Die/Thick Turret Die/D	RO Φ 60+0.45/slughugger-1
	2 Slots	Die/Thick Turret Die/D	RE 5*60+0.4/slughugger-1
	2 Slots	Die/Thick Turret Die/D/M2	RE 5*80+0.3/slughugger-1
	2 Slots	Die/Thick Turret Die/D/(0,90)	SQ 45*45+0.3/slughugger
	2 Slots	Die/Thick Turret Die/D/(0,135)	SQ 45*45+0.3/slughugger
	4 Slots	Die/Thick Turret Die/D/(0,45,90)	OB Φ 5*60+0.25/slughugger
3# Die/Thick Turret Vaccum Die			
	1 Slot	Die/TT Vaccum Die/D	RO Φ 52+0.15
	2 Slots	Die/TT Vaccum Die/D	RE 5*80+0.2
	2 Slots	Die/TT Vaccum Die/D/(0,90)	SQ 50*50+0.2
	2 Slots	Die/TT Vaccum Die/D/(0,135)	SQ 50*50+0.4
	2 Slots	Die/TT Vaccum Die/D	HX S=50+0.3
	4 Slots	Die/TT Vaccum Die/D/(0,45,90)	OB Φ 5*60+0.25
4# Die/Thick Turret Heavy Duty Die			
	1 Slot	Die/TT Heavy Duty Die/D	RO Φ 52+0.15
	1 Slot	Die/TT Heavy Duty Die/D/(0)	SQ 47*47*R5+1.0
	2 Slots	Die/TT Heavy Duty Die/D	RE 5*80+0.8
	2 Slots	Die/TT Heavy Duty Die/D/(0,90)	SQ 30*30*R2+0.6
	2 Slots	Die/TT Heavy Duty Die/D/(0,135)	SQ 30*30+0.4
	4 Slots	Die/TT Heavy Duty Die/D/(0,180)	Class C 18.5*4.9+0.15
5# Die/Thick Turret Close To Clamp Die			
	2 Slots	Die/TT Single Side CTC Die/D	RE 5*80+0.15
	2 Slots	Die/TT Single Side CTC Die/D	OB Φ 5*60+0.25
	2 Slots	Die/TT Single Side CTC Die/D	RE 5*80+0.2
	2 Slots	Die/TT Single Side CTC Die/D/LD	OB Φ 5*60+0.25
	2 Slots	Die/TT Double-Side CTC Die/D	RE 5*75+0.4
	2 Slots	Die/TT Double-Side CTC Die/D	OB Φ 5*60+0.25
	2 Slots	Die/TT Double-Side CTC Vaccum Die/D	RE 5*80+0.4
	2 Slots	Die/TT Double-Side CTC Vaccum Die/D	OB Φ 5*60+0.25
6# Die/Thick Turret Die/Blanking			
	1 Slot	Die/Thick Turret Die/D/Blanking	RO Φ 86.2
	1 Slot	Die/Thick Turret Die/D/Blanking	RO Φ 70
	2 Slots	Die/Thick Turret Die/D/Blanking	OB Φ 5*60
	2 Slots	Die/Thick Turret Die/D/Blanking	RE 5*80*R5
	2 Slots	Die/Thick Turret Die/D/Blanking	Class A/A15/A*B
	2 Slots	Die/Thick Turret Die/D/Blanking	Class C FT/A*B
7# Die/Thick Turret Cluster Die			
	2 Slots	Die/Thick Turret Cluster Die/D	
	2 Slots	Die/Thick Turret Cluster Die/D/M2	
	2 Slots	Die/Thick Turret Heavy Duty Cluster Die/D	
	2 Slots	Die/Thick Turret Vaccum Die/D	
8# Die/Thick Turret Special Die			
	1 Slot	Die/Thick Turret Blank Die/D	
	1 Slot	Die/Thick Turret Roller Ball Die/D	
	1 Slot	Die/Thick Turret Brush Die/D	

THICK TURRET
D STN

D STN (Size Range:ΦD:50.81~88.9mm)

D STN Guide

1# Guide/Thick Turret 85 Guide/D/(0,90)



2# Guide/Thick Turret 90 Guide/D/(0,90,225)



3# Guide/TT 85 Fully Guided Guide/D/(0,90)

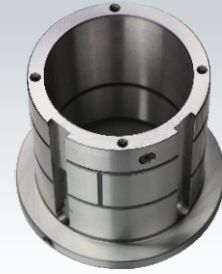

4# Guide/Thick Turret K85Guide/D/(0,90,225)



5# Guide/Thick Turret HR CTCGuide/D/(0,90)



THICK TURRET
D STN

D STN Punch Head Ass'y

1# PHA/TT T85 PHA/D



2# PHA/TT T85 ABS PHA/D

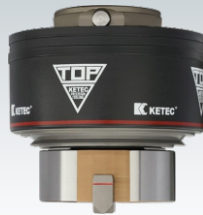

3# PHA/TT T90 PHA/D



4# PHA/TT HL 85 LD PHA/D

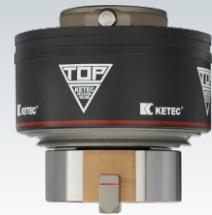

D STN Guide Ass'y

1# GA/TT E85 Guide Ass'y/D



2# Guide Ass'y/T85 Guide Ass'y/D



3# GA/TT T85 ABS Guide Ass'y/D



4# GA/TT T90Guide Ass'y/D



5# GA/TT T90 ABS Guide Ass'y/D



6# GA/TT HL 85 LD Guide Ass'y/D



7# GA/TT T85 Fully Guided GA/D



8# GA/TT HR CTC Guide Ass'y/D



E STN (Size Range:ΦD:88.91~114.3mm)

T85 E STN	Slot	Description	Size(e.g.)
1# Punch Ass'y/Thick Turret T85 Punch Ass'y			
	2 Slots	PA/Thick Turret T85 PA/E	RO Φ114
	2 Slots	PA/Thick Turret T85 PA/E	RE 5*100
	2 Slots	PA/Thick Turret T85 PA/E	OB Φ6*100/Rooftop
	2 Slots	PA/Thick Turret T85 PA/E	SQ 60*60/Concave
	2 Slots	PA/Thick Turret T85 PA/E	HX S=60
	2 Slots	PA/Thick Turret T85 PA/E	Class C FT/A*B
	2 Slots	PA/Thick Turret T85 PA/E	Class B B11/A*B
	2 Slots	PA/Thick Turret T85 PA/E/TiCN	Class A A5/A*B
	2 Slots	PA/Thick Turret T85 PA/E/TiCN	RE 5*100/Rooftop
	2 Slots	PA/Thick Turret T85 PA/E/TiCN	OB Φ6*100
	2 Slots	PA/Thick Turret T85 PA/E/TiCN	SQ 60*60
	2 Slots	PA/Thick Turret T85 PA/16T/E	RE 5*100
	2 Slots	PA/Thick Turret T85 PA/16T/E	RE 5*100/Rooftop
	2 Slots	PA/Thick Turret T85 PA/16T/E/TiCN	OB Φ6*100
	2 Slots	PA/Thick Turret T85 PA/16T/E/TiCN	OB Φ6*100/Rooftop
2 Slots	PA/Thick Turret T85 PA/E/Blanking	RE 5*100-0.2	
1.1# Punch/Thick Turret 85 Punch			
	1 Slot	Punch/TT 85 Punch/E	RO Φ100
	1 Slot	Punch/TT 85 Punch/E	OB Φ10*100/Rooftop/Rubber Pin
	1 Slot	Punch/TT 85 Punch/E	RE 6*110
	1 Slot	Punch/TT 85 Punch/E(45)	RE 5*100
	1 Slot	Punch/TT 85 Punch/E/TiCN	RE 6*110/Rooftop
	1 Slot	Punch/TT 85 Punch/E/TiCN	SQ 60*60
	1 Slot	Punch/TT 85 Punch/E/DF	HX S=60
	2 Slots	Punch/TT 85 Punch/E/(0,180)	Class C FT/A*B
	2 Slots	Punch/TT 85 Punch/E/TiCN/(0,180)	Class B B13/A*B
	1 Slot	Punch/TT 85 Punch/E/Blanking	RE 6*110-0.2
1.2# Punch/Thick Turret 85 Slitting Punch/16 Type			
	1 Slot	Punch/TT 85 Slitting Punch/16T/E	RE 5*100
	1 Slot	Punch/TT 85 Slitting Punch/16T/E	RE 5*100/Rooftop
	1 Slot	Punch/TT 85 Slitting Punch/16T/E/TiCN	OB Φ6*100
	1 Slot	Punch/TT 85 Slitting Punch/16T/E/TiCN	OB Φ6*100/Rooftop
	1 Slot	Punch/TT 85 Slitting Punch/16T/E/DF	RE 8*100
	1 Slot	Punch/TT 85 Slitting Punch/16T/E/DF	RE 8*100/Rooftop
1.3# Stripper/Thick Turret 85 Stripper			
	Stripper/Thick Turret 85Stripper/E		RO Φ100
	Stripper/Thick Turret 85Stripper/E		RE 5*100
	Stripper/Thick Turret 85Stripper/E		OB Φ6*100
	Stripper/Thick Turret 85Stripper/E		SQ 60*60
	Stripper/Thick Turret 85Stripper/E		HX S=60
	Stripper/Thick Turret 85Stripper/E		Class A/A*60°
	Stripper/Thick Turret 85Stripper/E		Class B B8/A*B*R
	Stripper/Thick Turret 85Stripper/E		Class C C4/ØD*A
	Stripper/Thick Turret 85Stripper/E/Blanking		RE 5*100-0.2

THICK TURRET
E STN

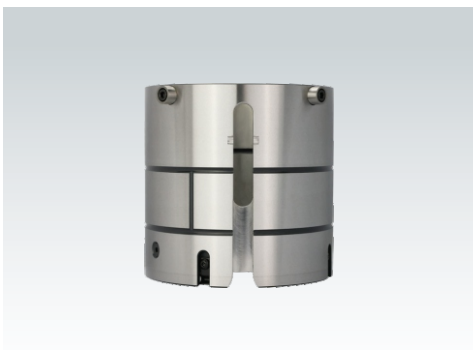

1.4# Guide Ass'y/Thick Turret T85 Guide Ass'y/E 1.5# Guide/Thick Turret 90 Guide/E/(0,90) 1.6# PHA/Thick Turret T85 Punch Head Ass'y/E

E STN (Size Range:ΦD:88.91~114.3mm)

T85 ABS E STN	Slot	Description	Size (e.g.)
2# Punch Ass'y/Thick Turret T85 ABS Punch Ass'y			
	2 Slots	PA/TT T85 ABS PA/E	RO Φ114
	2 Slots	PA/TT T85 ABS PA/E	RE 5*100
	2 Slots	PA/TT T85 ABS PA/E	OB Φ6*100/Rooftop
	2 Slots	PA/TT T85 ABS PA/E	SQ 60*60/Concave
	2 Slots	PA/TT T85 ABS PA/E	HX S=60
	2 Slots	PA/TT T85 ABS PA/E	Class C FT/A*B
	2 Slots	PA/TT T85 ABS PA/E	RO 4 SlotsB6/ØD*A
	2 Slots	PA/TT T85 ABS PA/E/TiCN	Class A A16/A*B
	2 Slots	PA/TT T85 ABS PA/E/TiCN	RE 5*100/Rooftop
	2 Slots	PA/TT T85 ABS PA/E/TiCN	OB Φ6*100
	2 Slots	PA/TT T85 ABS PA/E/TiCN	SQ 60*60
	2 Slots	PA/TT T85 ABS PA/16 T/E	RE 5*100
	2 Slots	PA/TT T85 ABS PA/16 T/E	RE 5*100/Rooftop
	2 Slots	PA/TT T85 ABS PA/16 T/E/TiCN	OB Φ6*100
	2 Slots	PA/TT T85 ABS PA/16 T/E/TiCN	OB Φ6*100/Rooftop
2 Slots	PA/TT T85 ABS PA/16 T/E/Blanking	RE 5*100-0.2	
2.1# Punch/Thick Turret 85 ABS Punch			
	1 Slot	Punch/TT 85 ABS Punch/E	RO Φ100
	1 Slot	Punch/TT 85 ABS Punch/E	OB Φ10*100/Rooftop/R-Pin
	1 Slot	Punch/TT 85 ABS Punch/E	RE 6*110
	1 Slot	Punch/TT 85 ABS Punch/E(45)	RE 5*110
	1 Slot	Punch/TT 85 ABS Punch/E/TiCN	RE 6*110/Rooftop
	1 Slot	Punch/TT 85 ABS Punch/E/TiCN	SQ 60*60
	1 Slot	Punch/TT 85 ABS Punch/E/DF	HX S=60
	2 Slots	Punch/TT 85 ABS Punch/E/(0,180)	Class C FT/A*B
	2 Slots	Punch/TT 85 ABS Punch/E/TiCN/(0,180)	Class BFT/A*B
	1 Slot	Punch/TT 85 ABS Punch/E/Blanking	RE 6*110-0.2
2.2# Stripper/Thick Turret 85 ABS Stripper			
	Stripper/TT 85 ABS Stripper/E		RO Φ100
	Stripper/TT 85 ABS Stripper/E		RE 5*100
	Stripper/TT 85 ABS Stripper/E		OB Φ6*100
	Stripper/TT 85 ABS Stripper/E		SQ 60*60
	Stripper/TT 85 ABS Stripper/E		HX S=60
	Stripper/TT 85 ABS Stripper/E		Class A D/A*B
	Stripper/TT 85 ABS Stripper/E		RO 2 Slot B4/ØD*A
	Stripper/TT 85 ABS Stripper/E		Class C FT/A*B
	Stripper/TT 85 ABS Stripper/E/Blanking		RE 5*100-0.2

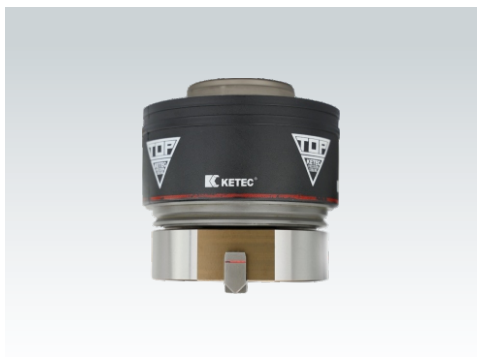

2.3# Guide Ass'y/TT T85 ABS Guide Ass'y/E

2.4# Guide/TT 90Guide/E/(0,90)

2.5# PHA/TT T85ABS PHA/E

E STN (Size Range:ΦD:88.91 ~ 114.3mm)

T85 Fully Guided E STN	Slot	Description	Size(e.g.)
3# Punch Ass'y/Thick Turret T85 Fully Guided Punch Ass'y			
	2 Slots	PA/TT T85 Fully Guided PA/E	RE 5*100
	2 Slots	PA/TT T85 Fully Guided PA/E	RE 5*100/Rooftop
	2 Slots	PA/TT T85 Fully Guided PA/E	OB Φ6*100
	2 Slots	PA/TT T85 Fully Guided PA/E	OB Φ6*100/Rooftop
	2 Slots	PA/TT T85 Fully Guided PA/E/TiCN	RE 8*100
	2 Slots	PA/TT T85 Fully Guided PA/E/TiCN	RE 8*100/Rooftop
	2 Slots	PA/TT T85 Fully Guided PA/16 Type/E	OB Φ5*100
	2 Slots	PA/TT T85 Fully Guided PA/16 Type/E	OB Φ5*100/Rooftop
	2 Slots	PA/TT T85 Fully Guided PA/16/E/TiCN	RE 6*100
	2 Slots	PA/TT T85 Fully Guided PA/16/E/TiCN	RE 6*100/Rooftop
3.1# Punch/Thick Turret 85 Punch			
	1 Slot	Punch/TT 85Punch/E	RE 5*100
	1 Slot	Punch/TT 85Punch/E	RE 5*100/Rooftop
	1 Slot	Punch/TT 85Punch/E/TiCN	OB Φ6*100
	1 Slot	Punch/TT 85Punch/E/TiCN	OB Φ6*100/Rooftop
	1 Slot	Punch/TT 85Punch/E/DF	RE 8*100
	1 Slot	Punch/TT 85Punch/E/DF	RE 8*100
3.2# Punch/Thick Turret 85 Slitting Punch/16 Type			
	1 Slot	Punch/TT 85 C-Punch/16 T/E	RE 5*100
	1 Slot	Punch/TT 85 C-Punch/16 T/E	RE 6*100/Rooftop
	1 Slot	Punch/TT 85 C-Punch/16 T/E/TiCN	RE 6*100
	1 Slot	Punch/TT 85 C-Punch/16 T/E/TiCN	RE 5*100
	1 Slot	Punch/TT 85 C-Punch/16 T/E/DF	OB Φ6*100
	1 Slot	Punch/TT 85 C-Punch/16 T/E/DF	OB Φ6*100/Rooftop
3.3# Stripper/Thick Turret 85 Fully Guided Stripper			
	Stripper/TT 85 Fully Guided Stripper/E	RE 5*100	
	Stripper/TT 85 Fully Guided Stripper/E	OB Φ6*100	
	Stripper/TT 85 Fully Guided Stripper/E	RE 8*100	
	Stripper/TT 85 Fully Guided Stripper/E		

THICK TURRET E STN



3.4# Guide Ass'y/TT T85 FG Guide Ass'y/E



3.5# Guide/Thick Turret 85 FG Guide/E(0,90)



3.6# PHA/TT T85 PHA/E

E STN (Size Range:ΦD:88.91~114.3mm)

T90 E STN	Slot	Description	Size (e.g.)	
6# Punch Ass'y/Thick Turret T90 Punch Ass'y				
	2 Slots	PA/TT T90 PA/E	RO Φ114	
	2 Slots	PA/TT T90 PA/E	RE 5*100	
	2 Slots	PA/TT T90 PA/E	OB Φ6*100/Rooftop	
	2 Slots	PA/TT T90 PA/E	SQ 60*60/Concave	
	2 Slots	PA/TT T90 PA/E	HX S=60	
	2 Slots	PA/TT T90 PA/E	Class C FT/A*B	
	2 Slots	PA/TT T90 PA/E	One Way Radius B7/A*B*R	
	2 Slots	PA/TT T90 PA/E/TiCN	Class A12/A*B	
	2 Slots	PA/TT T90 PA/E/TiCN	RE 5*100/Rooftop	
	2 Slots	PA/TT T90 PA/E/TiCN	OB Φ6*100	
	2 Slots	PA/TT T90 PA/E/TiCN	SQ 60*60	
	2 Slots	PA/TT T90 PA/E/TiCN	RE 5*100-0.2	
		*** PA: Punch Ass'y		
		*** TT: Thick Turret		
	*** TiCN: Coating			
6.1# Punch/Thick Turret 90 Punch				
	Pin	Punch/TT 90 Punch/E	RO Φ100	
	Pin	Punch/TT 90 Punch/E	RO Φ100/Concave	
	Pin	Punch/TT 90 Punch/E	OB Φ10*100/Rooftop/Rubber	
	Pin	Punch/TT 90 Punch/E/TiCN	RE 6*110	
	Pin	Punch/TT 90 Punch/E/TiCN	RE 6*110/Rooftop	
	Pin	Punch/TT 90 Punch/E/TiCN	HX S=60	
	Pin	Punch/TT 90 Punch/E/DF	SQ 60*60/Concave	
	Pin	Punch/TT 90 Punch/E/DF	Class BFT/A*B	
	Pin	Punch/TT 90 Punch/E/Blanking	RO Φ100-0.2	
		*** TT: Thick Turret		
	*** TiCN: Coating			
	*** DF: Deep Frozen			
6.2# Stripper/Thick Turret 90 Stripper				
		Stripper/TT 90 Stripper/E	RO Φ100	
		Stripper/TT 90 Stripper/E	RE 5*100	
		Stripper/TT 90 Stripper/E	OB Φ6*100/Rooftop	
		Stripper/TT 90 Stripper/E	SQ 60*60	
		Stripper/TT 90 Stripper/E	HX S=60	
		Stripper/TT 90 Stripper/E	Class A A1/A*B	
		Stripper/TT 90 Stripper/E	Class B B21/A*B	
		Stripper/TT 90 Stripper/E	Class C FT/A*B	
		Stripper/TT 90 Stripper/E/Blanking	RE 5*100-0.3	
		*** TT: Thick Turret		



6.3# Guide Ass'y/TT T90 Guide Ass'y/E



6.4# Guide/TT 90 Guide/E/(0,90)



6.5# PHA/Thick Turret T90 PHA/E

E STN (Size Range:ΦD:88.91~114.3mm)

HL 85 Light Duty E STN	Slot	Description	Size规格(例)
4# Punch Ass'y/Thick Turret HL 85 Light Duty Punch Ass'y			
 <p>Light Duty (Blue)</p> <p>Middle Duty (Red)</p> <p>Heavy Duty (Green)</p>	2 Slots	PA/Thick Turret HL 85 LD PA/E	RO Φ114
	2 Slots	PA/Thick Turret HL 85 LD PA/E	RE 5*100
	2 Slots	PA/Thick Turret HL 85 LD PA/E	OB Φ6*100/Rooftop
	2 Slots	PA/Thick Turret HL 85 LD PA/E	SQ 60*60/Concave
	2 Slots	PA/Thick Turret HL 85 LD PA/E	HX S=60
	2 Slots	PA/Thick Turret HL 85 LD PA/E	Class C FT/A*B
	2 Slots	PA/Thick Turret HL 85 LD PA/E	Class B B12/A*B
	2 Slots	PA/Thick Turret HL 85 LD PA/E/TiCN	Class A A6/A*B
	2 Slots	PA/Thick Turret HL 85 LD PA/E/TiCN	RE 5*100/Rooftop
	2 Slots	PA/Thick Turret HL 85 LD PA/E/TiCN	OB Φ6*100
	2 Slots	PPA/Thick Turret HL 85 LD PA/E/TiCN	SQ 60*60
	2 Slots	PA/Thick Turret HL 85 LD PA/16T/E	RE 5*100
	2 Slots	PA/Thick Turret HL 85 LD PA/16T/E	RE 5*100/Rooftop
	2 Slots	PA/Thick Turret HL 85 LD PA/16T/E/TiCN	OB Φ6*100
2 Slots	PA/Thick Turret HL 85 LD PA/16T/E/TiCN	OB Φ6*100/Rooftop	
4.1# Punch/Thick Turret 85 Punch			
	1 Slot	Punch/Thick Turret 85 Punch/E	RO Φ100
	1 Slot	Punch/Thick Turret 85 Punch/E	OB Φ10*100/Rooftop/Rubber Pin
	1 Slot	Punch/Thick Turret 85 Punch/E	RE 6*110
	1 Slot	Punch/Thick Turret 85 Punch/E/TiCN	RE 6*110/Rooftop
	1 Slot	Punch/Thick Turret 85 Punch/E/TiCN	SQ 60*60
	1 Slot	Punch/Thick Turret 85 Punch/E/DF	HX S=60
	2 Slots	Punch/Thick Turret 85 Punch/E/(0.180)	Class C FT/A*B
	2 Slots	Punch/TT 85 Punch/E/TiCN/(0.180)	Class B FT/A*B
4.2# Punch/Thick Turret 85 Slitting Punch/16 Type			
	1 Slot	Punch/TT 85 Slitting Punch/16T/E	RE 5*100
	1 Slot	Punch/TT 85 Slitting Punch/16T/E	RE 5*100
	1 Slot	Punch/TT 85 Slitting Punch/16T/E/TiCN	OB Φ6*100
	1 Slot	Punch/TT 85 Slitting Punch/16T/E/TiCN	OB Φ6*100/Rooftop
	1 Slot	Punch/TT 85 Slitting Punch/16T/E/DF	RE 8*100
	1 Slot	Punch/TT 85 Slitting Punch/16T/E/DF	RE 8*100/Rooftop
4.3# Stripper/Thick Turret 85 Stripper			
	Stripper/Thick Turret 85 Stripper/E		RO Φ100
	Stripper/Thick Turret 85 Stripper/E		RE 5*100
	Stripper/Thick Turret 85 Stripper/E		OB Φ6*100
	Stripper/Thick Turret 85 Stripper/E		SQ 60*60
	Stripper/Thick Turret 85 Stripper/E		HX S=60
	Stripper/Thick Turret 85 Stripper/E		Class A A7/A*B
	Stripper/Thick Turret 85 Stripper/E		Class B B9/A*B*R
	Stripper/Thick Turret 85 Stripper/E		Class C FT/A*B

THICK TURRET
E STN

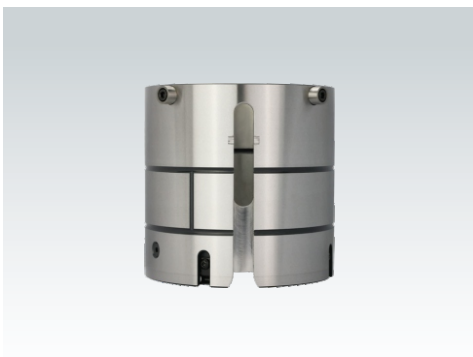

4.4# GA/Thick Turret HL 85 LD Guide Ass'y/E

4.5# Guide/Thick Turret 90 Guide/E(0,90)

4.6# PHA/Thick Turret HL 85 LD PHA/E

E STN (Size Range:ΦD:88.91~114.3mm)

Close To Clamp E STN	Slot	Description	Size (e.g.)
5# Punch Ass'y/Thick Turret HR Close To Clamp Punch Ass'y/E			
	2 Slots	PA/TT HR CTC PA/E	RE 5*100
	2 Slots	PA/TT HR CTC PA/E	RE 5*100/Rooftop
	2 Slots	PA/TT HR CTC PA/E/TiCN	OB Φ6*100
	2 Slots	PA/TT HR CTC PA/E/TiCN	OB Φ6*100/Rooftop
	2 Slots	PA/TT HR CTC PA/E/DF	RE 8*100
	2 Slots	PA/TT HR CTC PA/E/DF	RE 8*100/Rooftop
		*** PA: Punch Ass'y	
		*** TT: Thick Turret	
		*** HR: System Code	
		*** CTC: Close To Clamp	
		*** DF: Deep Frozen	
		*** TiCN: Coating	
5.1# Punch/Thick Turret HR Close To Clamp Punch			
	1 Slot	Punch/TT HR CTC Punch/E	RE 5*100
	1 Slot	Punch/TT HR CTC Punch/E	RE 5*100/Rooftop
	1 Slot	Punch/TT HR CTC Punch/E/TiCN	OB Φ6*100
	1 Slot	Punch/TT HR CTC Punch/E/TiCN	OB Φ6*100/Rooftop
	1 Slot	Punch/TT HR CTC Punch/E/DF	RE 8*100
	1 Slot	Punch/TT HR CTC Punch/E/DF	RE 8*100/Rooftop
		*** TT: Thick Turret	
		*** HR: System Code	
		*** CTC: Close To Clamp	
		*** DF: Deep Frozen	
		*** TiCN: Coating	
5.2# Stripper/Thick Turret HR Close To Clamp Stripper			
		Stripper/TT HR CTC Stripper/E	RE 5*100
		Stripper/TT HR CTC Stripper/E	OB Φ6*100
		Stripper/TT HR CTC Stripper/E	RE 8*100
		*** TT: Thick Turret	
		*** HR: System Code	
		*** CTC: Close To Clamp	



*** TT: Thick Turret
 *** HR: System Code
 *** CTC: Close To Clamp

5.3# Guide Ass'y/TT HR CTC Guide Ass'y/E

5.4# Guide/TT HR CTC Guide/E/(0,90)

E STN (Size Range:ΦD:88.91 ~ 114.3mm)

T90 ABS E STN	Slot	Description	Size(e.g.)	
7# Punch Ass'y/Thick Turret T90 ABS Punch Ass'y				
	2 Slots	PA/TT T90 ABS PA/E	RO Φ114	
	2 Slots	PA/TT T90 ABS PA/E	RE 5*100	
	2 Slots	PA/TT T90 ABS PA/E	OB Φ6*100/Rooftop	
	2 Slots	PA/TT T90 ABS PA/E	SQ 60*60/Concave	
	2 Slots	PA/TT T90 ABS PA/E	HX S=60	
	2 Slots	PA/TT T90 ABS PA/E	Class C FT/A*B	
	2 Slots	PA/TT T90 ABS PA/E	Class B16/A*B	
	2 Slots	PA/TT T90 ABS PA/E/TiCN	Class A4/A*B	
	2 Slots	PA/TT T90 ABS PA/E/TiCN	RE 5*100/Rooftop	
	2 Slots	PA/TT T90 ABS PA/E/TiCN	OB Φ6*100	
	2 Slots	PA/TT T90 ABS PA/E/TiCN	SQ 60*60	
			*** PA: Punch Ass'y	
			*** TT: Thick Turret	
		*** ABS: ABS		
		*** TiCN: Coating		
7.1# Punch/Thick Turret 90 Punch				
	Pin	Punch/TT 90 Punch/E	RO Φ100	
	Pin	Punch/TT 90 Punch/E	RO Φ100/Concave	
	Pin	Punch/TT 90 Punch/E	OB Φ10*100/Rooftop/Rubber	
	Pin	Punch/TT 90 Punch/E/TiCN	RE 6*110	
	Pin	Punch/TT 90 Punch/E/TiCN	RE 6*110/Rooftop	
	Pin	Punch/TT 90 Punch/E/TiCN	HX S=60	
	Pin	Punch/TT 90 Punch/E/DF	SQ 60*60/Concave	
	Pin	Punch/TT 90 Punch/E/DF	Class BFT/A*B	
			*** PA: Punch Ass'y	
			*** TT: Thick Turret	
		*** TiCN: Coating		
		*** DF: Deep Frozen		
7.2# Stripper/Thick Turret 90 ABS Stripper				
		Stripper/TT 90 ABS Stripper/E	RO Φ100	
		Stripper/TT 90 ABS Stripper/E	RE 5*100	
		Stripper/TT 90 ABS Stripper/E	OB Φ6*100/Rooftop	
		Stripper/TT 90 ABS Stripper/E	SQ 60*60	
		Stripper/TT 90 ABS Stripper/E	HX S=60	
		Stripper/TT 90 ABS Stripper/E	HX S=A9/A*B	
		Stripper/TT 90 ABS Stripper/E	Class B14/A*B	
		Stripper/TT 90 ABS Stripper/E	Class C FT/A*B	
			*** ABS: ABS	

THICK TURRET
E STN



7.3# Guide Ass'y/TT T90 ABS Guide Ass'y/E



7.4# Guide/TT 90 Guide/E(0,90)



7.5# PHA/TT T90 PHA/E

*** ABS: ABS

*** TT: Thick Turret

*** PHA: Punch Head Ass'y

E STN (Size Range: $\Phi D: 88.91 \sim 114.3\text{mm}$)

E85 E STN	Slot	Description	Size (e.g.)
8# Punch Ass'y/Thick Turret E85 Punch Ass'y			
	2 Slots	PA/TT E85 PA/E	RO $\Phi 114$
	2 Slots	PA/TT E85 PA/E	RE 5*100
	2 Slots	PA/TT E85 PA/E	OB $\Phi 6^*100$ /Rooftop
	2 Slots	PA/TT E85 PA/E	SQ 60*60/Concave
	2 Slots	PA/TT E85 PA/E	HX S=60
	2 Slots	PA/TT E85 PA/E	Class C FT/A*B
	2 Slots	PA/TT E85 PA/E	Class C 18/A*B
	2 Slots	PA/TT E85 PA/E/TiCN	Class C 6/A*B
	2 Slots	PA/TT E85 PA/E/TiCN	RE 5*100/Rooftop
	2 Slots	PA/TT E85 PA/E/TiCN	OB $\Phi 6^*100$
	2 Slots	PA/TT E85 PA/E/TiCN	SQ 60*60
	2 Slots	PA/TT E85 PA/16 Type/E	RE 5*100
	2 Slots	PA/TT E85 PA/16 Type/E	RE 5*100/Rooftop
	2 Slots	PA/TT E85 PA/16 Type/E/TiCN	OB $\Phi 6^*100$
	2 Slots	PA/TT E85 PA/16 Type/E/TiCN	OB $\Phi 6^*100$ /Rooftop
2 Slots	PA/TT E85 PA/16 Type/E/Blanking	RE 5*100-0.2	
*** PA: Punch Ass'y *** TT: Thick Turret *** TiCN: Coating			
8.1# Punch/Thick Turret 85 Punch			
	1 Slot	Punch/TT 85 Punch/E	RO $\Phi 100$
	1 Slot	Punch/TT 85 Punch/E	OB $\Phi 10^*100$ /Rooftop/R-Pin
	1 Slot	Punch/TT 85 Punch/E	RE 6*110
	1 Slot	Punch/TT 85 Punch/E(45)	RE 5*100
	1 Slot	Punch/TT 85 Punch/E/TiCN	RE 6*110/Rooftop
	1 Slot	Punch/TT 85 Punch/E/TiCN	SQ 60*60
	1 Slot	Punch/TT 85 Punch/E/DF	HX S=60
	2 Slots	Punch/TT 85 Punch/E/(0,180)	Class C FT/A*B
	2 Slots	Punch/TT 85 Punch/E/TiCN/(0,180)	Class BFT/A*B
	1 Slot	Punch/TT 85 Punch/E/Blanking	RE 6*110-0.2
8.2# Punch/Thick Turret 85 Slitting Punch/16 Type			
	1 Slot	Punch/TT 85 Slitting Punch/16 Type/E	RE 5*100
	1 Slot	Punch/TT 85 Slitting Punch/16 Type/E	RE 5*100/Rooftop
	1 Slot	Punch/TT 85 S-Punch/16 Type/E/TiCN	OB $\Phi 6^*100$
	1 Slot	Punch/TT 85 S-Punch/16 Type/E/TiCN	OB $\Phi 6^*100$ /Rooftop
	1 Slot	Punch/TT 85 S-Punch/16 Type/E/DF	RE 8*100
	1 Slot	Punch/TT 85 S-Punch/16 Type/E/DF	RE 8*100/Rooftop
*** TiCN: Coating *** S-Punch: Slitting Punch *** TT: Thick Turret			
8.3# Stripper/Thick Turret 85 Stripper			
	Stripper/TT 85 Stripper/E	RO $\Phi 100$	
	Stripper/TT 85 Stripper/E	RE 5*100	
	Stripper/TT 85 Stripper/E	OB $\Phi 6^*100$	
	Stripper/TT 85 Stripper/E	SQ 60*60	
	Stripper/TT 85 Stripper/E	HX S=60	
	Stripper/TT 85 Stripper/E	Class C 14/A*B	
	Stripper/TT 85 Stripper/E	Class C 18/A*B	
	Stripper/TT 85 Stripper/E	Class C FT/A*B	
	Stripper/TT 85 Stripper/E/Blanking	RE 5*100-0.2	
*** TT: Thick Turret			

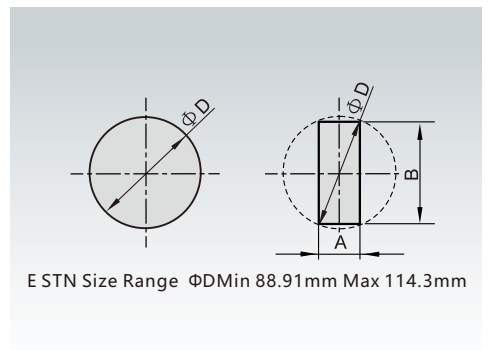

8.4# Guide Ass'y/Thick Turret E85 Guide Ass'y/E

8.5# Guide/Thick Turret 85 Guide/E(0,90)

E STN (Size Range:ΦD:88.91 ~ 114.3mm)

E STN Punch	Slot	Description	Size(e.g.)
1# Punch/Thick Turret 85 Punch			
	1 Slot	Punch/TT 85 Punch/E	RO Φ114
	1 Slot	Punch/TT 85 Punch/E/Blanking	RE 5*100-0.2
	1 Slot	Punch/TT 85 Punch/E	OB Φ6*100/Rooftop
	1 Slot	Punch/TT 85 Punch/E/(45)	RE 5*100
	1 Slot	Punch/TT 85 Punch/E/TiCN	SQ 60*60/Concave
	1 Slot	Punch/TT 85 Punch/E/TiCN	HX S=60
	1 Slot	Punch/TT 85 Punch/E/DF	RE 5*100/Rooftop
	1 Slot	Punch/TT 85 Punch/E/DF	OB Φ6*100
	2 Slots	Punch/TT 85 Punch/E/(0,180)	Class BFT/A*B
	2 Slots	Punch/TT 85 Punch/E/TiCN/(0,180)	Class C FT/A*B
2# Punch/Thick Turret 85 Slitting Punch/16 Type			
	1 Slot	Punch/TT 85 Slitting Punch/16 Type/E	RE 5*100/Rooftop
	1 Slot	Punch/TT 85 Slitting Punch/16 Type/E	RE 5*100
	1 Slot	Punch/TT 85 S-Punch/16 Type/E/TiCN	OB Φ6*100
	1 Slot	Punch/TT 85 S-Punch/16 Type/E/TiCN	OB Φ6*100/Rooftop
	1 Slot	Punch/TT 85 Slitting Punch/16 Type/E/DF	RE 5*100
	1 Slot	Punch/TT 85 Slitting Punch/16 Type/E/DF	OB Φ6*100
		*** TiCN: Coating	*** DF: Deep Frozen
	*** S-Punch: Slitting Punch		
	*** TT: Thick Turret		
3# Punch/Thick Turret 85 ABS Punch			
	1 Slot	Punch/TT 85 ABS Punch/E	RO Φ114
	1 Slot	Punch/TT 85 ABS Punch/E/Blanking	RE 5*100-0.2
	1 Slot	Punch/TT 85 ABS Punch/E	OB Φ6*100/Rooftop
	1 Slot	Punch/TT 85 ABS Punch/E/TiCN	SQ 60*60/Concave
	1 Slot	Punch/TT 85 ABS Punch/E/TiCN	HX S=60
	1 Slot	Punch/TT 85 ABS Punch/E/TiCN	RE 5*100/Rooftop
	1 Slot	Punch/TT 85 ABS Punch/E/DF	OB Φ6*100
	1 Slot	Punch/TT 85 ABS Punch/E/DF	Class A A11/A*B
	2 Slots	Punch/TT 85 ABS Punch/E/(0,180)	Class BFT/A*B
	2 Slots	Punch/TT 85 ABS Punch/E/TiCN/(0,180)	Class C FT/A*B
4# Punch/Thick Turret 90 Punch			
	Pin	Punch/TT 90 Punch/E	RO Φ90
	Pin	Punch/TT 90 Punch/E	RO Φ90/Concave
	Pin	Punch/TT 90 Punch/E	RE 5*110/Rooftop
	Pin	Punch/TT 90 Punch/E	Class A13/A*B
	Pin	Punch/TT 90 Punch/E	Class BFT/A*B
	Pin	Punch/TT 90 Punch/E	Class C FT/A*B
	Pin	Punch/TT 90 Punch/E/TiCN	RE 6*110
	Pin	Punch/TT 90 Punch/E/TiCN	OB Φ6*100
	Pin	Punch/TT 90 Punch/E/LD/TiCN	SQ 50*50/Rooftop
5# Punch/TT HR Close To Clamp Punch			
	1 Slot	Punch/TT HR CTC Punch/E	RE 5*100
	1 Slot	Punch/TT HR CTC Punch/E	RE 5*100/Rooftop
	1 Slot	Punch/TT HR CTC Punch/E/TiCN	OB Φ6*100
	1 Slot	Punch/TT HR CTC Punch/E/TiCN	OB Φ6*100/Rooftop
	1 Slot	Punch/TT HR CTC Punch/E/DF	RE 5*100
	1 Slot	Punch/TT HR CTC Punch/E/DF	OB Φ6*100
6# Punch/Thick Turret 85 Cluster Slitting Punch			
	Pin	Punch/TT 85 Cluster Slitting Punch/E	*** TT: Thick Turret
	Pin	Punch/TT 85 Cluster Slitting Punch/E	*** HR: System Code
	Pin	Punch/TT 85 Cluster Slitting Punch/E	*** CTC: Close To Clamp
	Pin	Punch/TT 85 Cluster Slitting Punch/E	*** DF: Deep Frozen
	Pin	Punch/TT 85 Cluster Slitting Punch/E	*** TiCN: Coating
	Pin	Punch/TT 85 Cluster Slitting Punch/E	

THICK TURRET
E STN

E STN (Size Range:ΦD:88.91~114.3mm)

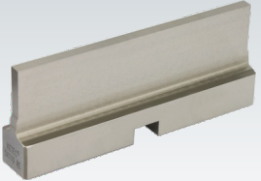
Slitting Punch Blade	Description	Size(e.g.)
7# Slitting Punch Blade/Thick Turret Slitting Punch Blade 16/18/19/20 Type		
	1 Slot Insert/Blade/TT 16T Punch Blade/E	RE 5*100
	1 Slot Insert/Blade/TT 16T Punch Blade/E/TiCN	OB Φ5*100/Rooftop
	1 Slot Insert/Blade/TT 18T Punch Blade/E	OB Φ5*110
	1 Slot Insert/Blade/TT 18T Punch Blade/E/TiCN	RE 10*100
	1 Slot Insert/Blade/TT 19T Punch Blade/E	OB Φ8*100
	1 Slot Insert/Blade/TT 19T Punch Blade/E/TiCN	RE 10*100
	1 Slot Insert/Blade/TT 20T Punch Blade/E	RE 5*110
	1 Slot Insert/Blade/TT 20T Punch Blade/E/TiCN	RE 5*110/Rooftop

Stripper	Description	Size(e.g.)
1# Stripper/Thick Turret 85 Stripper		
	Stripper/TT 85 Stripper/E	RE 5*100
	Stripper/TT 85 Stripper/E	OB Φ6*100
	Stripper/TT 85 Stripper/E	SQ 60*60
	Stripper/TT 85 Stripper/E	Class C FT/A*B
	Stripper/TT 85 Stripper/E	RO Φ100
	Stripper/TT 85 Stripper/E/Blanking	SQ 60*60-0.3
2# Stripper/Thick Turret 85 ABS Stripper		
	Stripper/TT 85 ABS Stripper/E	RE 5*100
	Stripper/TT 85 ABS Stripper/E	OB Φ6*100
	Stripper/TT 85 ABS Stripper/E	SQ 60*60
	Stripper/TT 85 ABS Stripper/E	Class C FT/A*B
	Stripper/TT 85 ABS Stripper/E	RO Φ100
	Stripper/TT 85 ABS Stripper/E/Blanking	SQ 60*60-0.2
3# Stripper/Thick Turret 85 Fully Guided Stripper		
	Stripper/TT 85 Fully Guided Stripper/E	RE 5*80
	Stripper/TT 85 Fully Guided Stripper/E	OB Φ6*80
4# Stripper/Thick Turret 90 Stripper		
	Stripper/TT 90 Stripper/E	RE 5*100
	Stripper/TT 90 Stripper/E	OB Φ6*100
	Stripper/TT 90 Stripper/E	SQ 60*60
	Stripper/TT 90 Stripper/E	Class C FT/A*B
	Stripper/TT 90 Stripper/E	RO Φ100
	Stripper/TT 90 Stripper/E/Blanking	RE 5*100-0.2

THICK TURRET
E STN

E STN (Size Range:ΦD:88.91~114.3mm)

E STN Stripper

E STN Stripper		Description	Size(e.g.)
5# Stripper/Thick Turret 90 ABS Stripper			
	Stripper/TT 90 ABS Stripper/E	RE 5*100	
	Stripper/TT 90 ABS Stripper/E	OB Φ6*100	
	Stripper/TT 90 ABS Stripper/E	SQ 60*60	
	Stripper/TT 90 ABS Stripper/E	Class C FT/A*B	
	Stripper/TT 90 ABS Stripper/E	RO Φ100	
	Stripper/TT 90 ABS Stripper/E/Blanking	SQ 60*60-0.2	

6# Stripper/Thick Turret Close To Clamp Stripper			
	Stripper/TT CTC Stripper/E	RE 5*100	
	Stripper/TT CTC Stripper/E	OB Φ6*100	

E STN Die

E STN Die		Description	Size(e.g.)
1# Die/Thick Turret Die			
	1 Slot Die/TT Die/E	RO Φ114+0.25	
	2 Slots Die/TT Die/E	RE 5*110+0.5	
	2 Slots Die/TT Die/E	OB Φ6*100+0.25	
	2 Slots Die/TT Die/E	RE 30*100*R5+0.5	
	2 Slots Die/TT Die/E	Class C FT/A*B+1.2	
	2 Slots Die/TT Die/E/(0,90)	SQ 40*40+0.3	
	2 Slots Die/TT Die/E/(0,135)	SQ 45*45+0.3	
	4 Slots Die/TT Die/E/(0,90,180,270)	Class A FT/A*B+0.2	

2# Die/Thick Turret Die/slughugger			
	1 Slot Die/TT Die/E	RO Φ114+0.25/slughugger-1	
	2 Slots Die/TT Die/E	RE 5*110+0.5/slughugger-1	
	2 Slots Die/TT Die/E	OB Φ6*100+0.25/slughugger-1	
	2 Slots Die/TT Die/E	RE 30*100*R5+0.5/slughugger	
	2 Slots Die/TT Die/E	Class C FT/A*B+1.2/slughugger	
	2 Slots Die/TT Die/E/(0,90)	SQ 40*40+0.3/slughugger	
	2 Slots Die/TT Die/E/(0,135)	SQ 45*45+0.3/slughugger	
	4 Slots Die/TT Die/E/(0,90,180,270)	Class C FT/A*B+0.2/slughugger	

3# Die/Thick Turret Vacuum Die			
	1 Slot Die/TT Vacuum Die/E	RO Φ114+0.25	
	2 Slots Die/TT Vacuum Die/E	RE 5*110+0.5	
	2 Slots Die/TT Vacuum Die/E	OB Φ6*100+0.25	
	2 Slots Die/TT Vacuum Die/E	RE 30*100*R5+0.5	
	2 Slots Die/TT Vacuum Die/E	Class C FT/A*B+0.3	
	2 Slots Die/TT Vacuum Die/E/(0,90)	SQ 40*40+0.3	
	2 Slots Die/TT Vacuum Die/E/(0,135)	SQ 45*45+0.3	
	4 Slots Die/TT Vacuum Die/E/(0,90,180,270)	Class BFT/A*B+0.2	

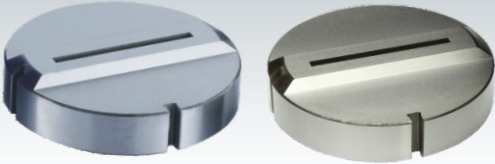
4# Die/Thick Turret Close To Clamp Die			
	2 Slots Die/TT Single Side CTC Die/E	RE 5*100+0.3	
	2 Slots Die/TT Single Side CTC Die/E	OB Φ6*100+0.3	
	2 Slots Die/TT Single Side CTC Vacuum Die/E	RE 5*110+0.3	
	2 Slots Die/TT Single Side CTC Vacuum Die/E	OB Φ6*100+0.3	
	2 Slots Die/TT Double-Side CTC Die/E	RE 5*100+0.2	
	2 Slots Die/TT Double-Side CTC Die/E	OB Φ6*100+0.3	
	2 Slots Die/TT Double-Side CTC Vacuum Die/E	RE 5*110+0.2	
	2 Slots Die/TT Double-Side CTC Vacuum Die/E	OB Φ6*100+0.3	

5# Die/Thick Turret Cluster Die			
	2 Slots Die/TT Cluster Die/E		
	2 Slots Die/TT Cluster Die/E/M2		
	2 Slots Die/TT Heavy Duty Cluster Die/E		
	2 Slots Die/TT Vacuum Cluster Die/E		

THICK TURRET
E STN

E STN (Size Range:ΦD:88.91~114.3mm)

E STN Guide

1# Guide/TT 85 Guide/E/(0,90)	2# Guide/TT 90 Guide/E/(0,90)	3# Guide/TT T85 Fully Guided Guide/E/(0,90)	4# Guide/TT HR CTC Guide/E/(0,90)

E STN Punch Head Ass'y

1# PHA/TT T85 PHA/E	2# PHA/TT T85 ABS PHA/E	3# PHA/TT 90 PHA/E	4# PHA/TT HI85 Light Duty PHA/E

E STN Guide Ass'y

1# Guide Ass'y/TT E85Guide Ass'y/E	2# Guide Ass'y/TT T85Guide Ass'y/E	3# GA/TT T85ABS GA/E	4# GA/TT T85 Fully Guided GA/E
5# GA/TT HL 85 Light Duty GA/E	6# GA/TT HR CTC Guide Ass'y/E	7# GA/TT T90 GA/E	8# GA/TT T90ABS GA/E

THICK TURRET
E STN

FinnPower Type Multi Tools

MT8/10/24	Type	Description	Size (e.g.)
1.1 Punch			
	(F)8	Multi Tool Punch/TT (F)8 Punch	RO $\Phi 22$
	(F)8	Multi Tool Punch/TT (F)8 Punch/TiCN	RO $\Phi 20$
	(F)8	Multi Tool Punch/TT (F)8 Punch/DF	RO $\Phi 20$
	(F)8	Multi Tool Punch/TT (F)8 Punch/DF/TiCN	RO $\Phi 20$
	(F)8	Multi Tool Punch/TT (F)8 Punch/H71/TiCN	RO $\Phi 22$
1.2 Stripper			
	(F)8	Multi Tool/TT (F)8 Stripper	RO $\Phi 15$
	(F)8	Multi Tool/TT (F)8 Stripper	RE 3*10
	(F)8	Multi Tool/TT (F)8 Stripper	SQ 15*15
1.3 Die			
	(F)8	Multi Tool Die/TT (F)8 Die	RO $\Phi 15+0.2$
	(F)8	Multi Tool Die/TT (F)8 Die	RE 5*10+0.2
	(F)8	Multi Tool Die/TT (F)8 Die	SQ 10*10+0.3
	(F)8	Multi Tool Die/TT (F)8 Die/(90)	OB $\Phi 9*20+0.3$
2.1 Punch			
	(F)10	Multi Tool Punch/TT (F)10 Punch	RO $\Phi 7$
	(F)10	Multi Tool Punch/TT (F)10 Punch/TiCN	RO $\Phi 7$
	(F)10	Multi Tool Punch/TT (F)10 Punch/DF	RO $\Phi 7$
	(F)10	Multi Tool Punch/TT (F)10 Punch/DF/TiCN	RO $\Phi 4.2$
	(F)10	Multi Tool Punch/TT (F)10 Punch/(90)	HX A=S=11.2
	(F)10	Multi Tool Punch/TT (F)10 Punch/H71/TiCN	RO $\Phi 12$
2.2 Stripper			
	(F)10	Multi Tool Stripper/TT (F)10 Stripper	RO $\Phi 10$
	(F)10	Multi Tool Stripper/TT (F)10 Stripper	RE 5*10
	(F)10	Multi Tool Stripper/TT (F)10 Stripper	SQ 7*7
2.3 Die			
	(F)10	Multi Tool Die/TT (F)10 Die	RO $\Phi 10+0.3$
	(F)10	Multi Tool Die/TT (F)10 Die	RE 3*10+0.3
	(F)10	Multi Tool Die/TT (F)10 Die	SQ 10*10+0.2
	(F)10	Multi Tool Die/TT (F)10 Die/(45)	SQ 5*5+0.2
	(F)10	Multi Tool Die/TT (F)10 Die/(90)	RE 4*12+0.12
3.1 Punch			
	(F)24	Multi Tool Punch/TT (F)24 Punch	RO $\Phi 5$
	(F)24	Multi Tool Punch/TT (F)24 Punch/TiCN	RO $\Phi 5$
	(F)24	Multi Tool Punch/TT (F)24 Punch/DF	RO $\Phi 5$
	(F)24	Multi Tool Punch/TT (F)24 Punch/DF/TiCN	RO $\Phi 1.5$
	(F)24	Multi Tool Punch/TT (F)24 Punch/TiCN/(45)	SQ 2.8*2.8
	(F)24	Multi Tool Punch/TT (F)24 Punch/H71/TiCN	RO $\Phi 5$
3.2 Stripper			
	(F)24	Multi Tool Stripper/TT (F)24 Stripper	RO $\Phi 5$
	(F)24	Multi Tool Stripper/TT (F)24 Stripper	RE 3*5
3.3 Die			
	(F)24	Multi Tool Die/TT (F)24 Die	RO $\Phi 5+0.2$
	(F)24	Multi Tool Die/TT (F)24 Die	RE 2*5+0.2
	(F)24	Multi Tool Die/TT (F)24 Die/(45)	SQ 5*5+0.2







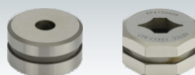

Euromac Type Multi Tools

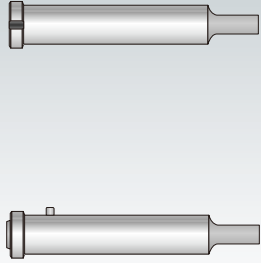
XMT12.7mm-24mm	Type	Description	Size (e.g.)
1.1 Punch			
	(E) 10	Multi Tool Punch/TT (E) 10 Punch	RO $\Phi 5$
	(E) 10	Multi Tool Punch/TT (E) 10 Punch/TiCN	RO $\Phi 5$
	(E) 10	Multi Tool Punch/TT (E) 10 Punch	RE 3*10
	(E) 10	Multi Tool Punch/TT (E) 10 Punch/TiCN	RE 3*10
	(E) 10	Multi Tool Punch/TT (E) 10 Punch/TiCN/(45)	SQ 5*5
	(E) 10	Multi Tool Punch/TT (E) 10 Punch/DF	HX A=S=6
	(E) 10	Multi Tool Punch/TT (E) 10 Adjustable Punch	RO $\Phi 12$
	(E) 10	Multi Tool Punch/TT (E) 10 Adjustable Punch/TiCN	RO $\Phi 12$
1.2 Stripper			
	(E) 10	Multi Tool Stripper/TT (E) 10 Stripper	RE 4*10
	(E) 10	Multi Tool Stripper/TT (E) 10 Stripper	RO $\Phi 5$
1.3 Die			
	(E) 10	Multi Tool Die/TT (E) 10 Die	RO $\Phi 10+0.2$
	(E) 10	Multi Tool Die/TT (E) 10 Die	RE 5*10+0.2
	(E) 10	Multi Tool Die/TT (E) 10 Die/(45)	SQ 5*5+0.3
2.1 Punch			
	(E) 6	Multi Tool Punch/TT (E) 6 Punch	RE 5*20
	(E) 6	Multi Tool Punch/TT (E) 6 Punch/TiCN	RE 5*20
	(E) 6	Multi Tool Punch/TT (E) 6 Punch/DF	RE 3*20
	(E) 6	Multi Tool Punch/TT (E) 6 Punch/DF/TiCN	SQ 7*7
	(E) 6	Multi Tool Punch/TT (E) 6 Adjustable Punch	RE 3*10
	(E) 6	Multi Tool Punch/TT (E) 6 Adjustable Punch/TiCN	RE 3*10
	(E) 6	Multi Tool Punch/TT (E) 6 Adjustable Punch/DF	RO $\Phi 2.5$
2.2 Stripper			
	(E) 6	Multi Tool Stripper/TT (E) 6 Stripper	RE 4*20
	(E) 6	Multi Tool Stripper/TT (E) 6 Stripper	RO $\Phi 2.5$
2.3 Die			
	(E) 6	Multi Tool Die/TT (E) 6 Die	RE 4*20+0.2
	(E) 6	Multi Tool Die/TT (E) 6 Die	RO $\Phi 2.5+0.2$
3.1 Stripper			
	(E) 4	Multi Tool Stripper /TT (E) 4 Stripper	RE 3*20
	(E) 4	Multi Tool Stripper /TT (E) 4 Stripper	RO $\Phi 2.5$

Durma Type Multi Tools

DMT24	Type	Description	Size (e.g.)
1.1 Punch			
	(D) 6	Multi Tool Punch/TT (D) 6 Punch	RE 4*20
	(D) 6	Multi Tool Punch/TT (D) 6 Punch/TiCN	RE 5*20
	(D) 6	Multi Tool Punch/TT (D) 6 Punch/DF	RE 2*20
	(D) 6	Multi Tool Punch/TT (D) 6 Punch/DF/TiCN	SQ 7*7
1.2 Stripper			
	(D) 6	Multi Tool Stripper/TT (D) 6 Stripper	RO $\Phi 20$
	(D) 6	Multi Tool Stripper/TT (D) 6 Stripper	RE 5*20

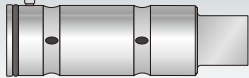
Wilson Type Multi Tools

MT8i1/MT8i2	Type	Description	Size(e.g.)
1.1 Punch			
	(W)8	Multi Tool Punch/TT (W)8 Punch	RO $\Phi 5$
	(W)8	Multi Tool Punch/TT (W)8 Punch/TiCN	RO $\Phi 5$
	(W)8	Multi Tool Punch/TT (W)8 Punch	RE 5*10
	(W)8	Multi Tool Punch/TT (W)8 Punch/TiCN	RE 5*10
	(W)8	Multi Tool Punch/TT (W)8 Punch	SQ 5*5
	(W)8	Multi Tool Punch/TT (W)8 Punch/TiCN	SQ 5*5
	(W)8	Multi Tool Punch/TT (W)8 Punch/With Pin & Step	RO $\Phi 5$
	(W)8	Multi Tool Punch/TT (W)8 Punch/With Pin & Step/TiCN	RO $\Phi 5$
	(W)8	Multi Tool Punch/TT (W)8 Punch/With Pin & Step	RE 5*10
	(W)8	Multi Tool Punch/TT (W)8 Punch/With Pin & Step/TiCN	RE 5*10
(W)8	Multi Tool Punch/TT (W)8 Punch/With Pin & Step	SQ 10*10	
(W)8	Multi Tool Punch/TT (W)8 Punch/With Pin & Step/TiCN	SQ 10*10	
1.2Stripper			
	(W)8	Multi Tool Stripper/TT (W)8 Stripper	RE 5*10
	(W)8	Multi Tool Stripper/TT (W)8 Stripper	RO $\Phi 5$
	(W)8	Multi Tool Stripper/TT (W)8 Stripper	SQ 5*5
1.3Die			
	(W)8	Multi Tool Die/TT (W)8 Die	RO $\Phi 10+0.2$
	(W)8	Multi Tool Die/TT (W)8 Die	RE 3*10+0.3
2.1Punch			
	(W)20	Multi Tool Punch/TT (W)20 Punch	RO $\Phi 5$
	(W)20	Multi Tool Punch/TT (W)20 Punch/TiCN	RO $\Phi 5$
	(W)20	Multi Tool Punch/TT (W)20 Punch	RE 4*6
	(W)20	Multi Tool Punch/TT (W)20 Punch/TiCN	RE 4*6
	(W)20	Multi Tool Punch/TT (W)20 Punch	SQ 4*4
	(W)20	Multi Tool Punch/TT (W)20 Punch/TiCN	SQ 4*4
2.2Stripper			
	(W)20		
	(W)20		
2.3Die			
	(W)20		
	(W)20		
3.1Punch			
	(W)3		
	(W)3		
3.2Stripper			
	(W)3	Multi Tool Stripper/TT (W)3 Stripper	RE 5*30
	(W)3	Multi Tool Stripper/TT (W)3 Stripper	RO $\Phi 20$
3.3Die			
	(W)3	Multi Tool Die/TT (W)3 Die	RO $\Phi 20+0.2$
	(W)3	Multi Tool Die/TT (W)3 Die	RE 3*10+0.2



Wechat Public Account

Homepage

[Http://www.ketecool.com](http://www.ketecool.com)

Global Standard: GB/T19001-2016/ISO9001:2015

广州市启泰模具工业有限公司
Ketec Precision Tooling Co.,Ltd.

Domestic Sales:+86 188 1981 5253(Mob) 020-3796 5586(Fax) E-mail:market@ketecool.com (Mail box)

Overseas Sales:+86 137 6069 2768(Mob) simon@ketecool.com(Mail box)

After sales service:020-3796 5692(Phone/Fax)

Address: No.7 Lifeng Road Mingzhu Industrial Park, Conghua, Guangzhou, China

All Rights Reserved@ KETEC Copyright 2021-Oversea Department Simon Office

2021Version (2021-10)